

*Consiglio Nazionale delle Ricerche*

**IEIIT – Istituto di Elettronica e di Ingegneria  
dell'Informazione e delle Telecomunicazioni  
c/o Politecnico di Torino, Italy**

# **Electromagnetic development of broadband antenna feeding arrays for the Northern Cross Radio Telescope**

**G. Virone, R. Tascone, O. A. Peverini,  
G. Addamo, A. Olivieri**



# IEIIT – CNR

Institute of Electronics and Information and Communication Engineering  
National Research Council

- 55 researchers
- 5 cities: Turin, Milan, Bologna, Genoa, Pisa
- Information and Communication Technology

## Applied Electromagnetics Group

IEIIT-Torino, Politecnico di Torino

- 4 researchers
- 3 technicians



# Recent Activities (1)

Ka-band dual polarization receiver

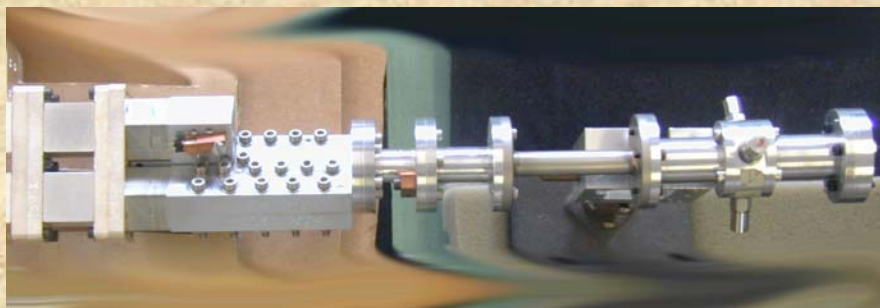

C-band dual polarization receiver (30% BW)

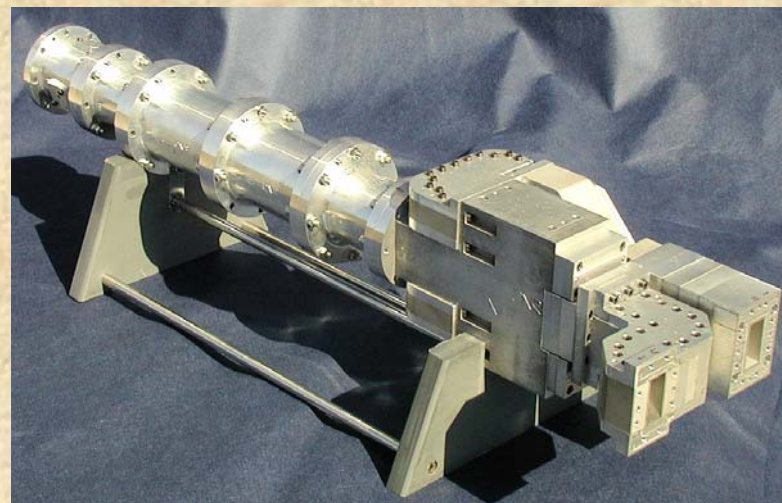

Ka-band analog correlation unit and filters

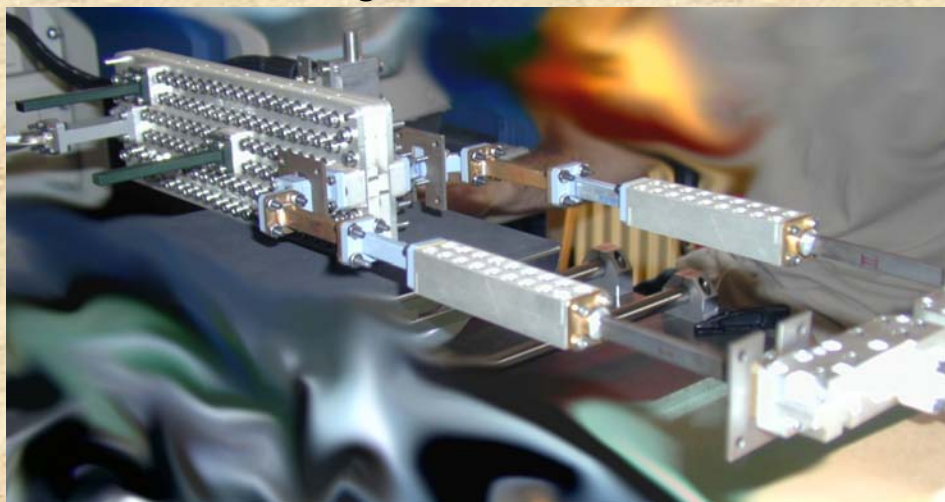

- Analysis and Design EM software
  - Full-wave integral techniques
  - Reduced Order Models
  - Synthesis methods

Measurement techniques



# Recent Activities (2)

Antenna Radomes



Courtesy of SITI Radomes Srl, (CO), Italy

Sundial - DBS - Antenna



Sensors for Industrial Applications

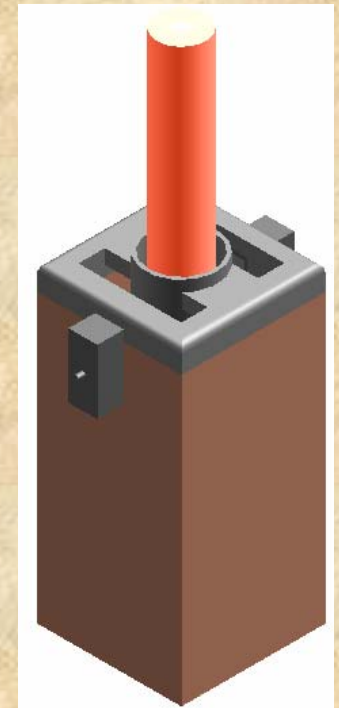

Leaky Coaxial Cables

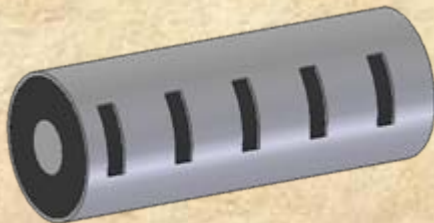

# EM design support in



# activities

- National Institute of Astrophysics (INAF)
- National Institute of Radio Astronomy (IRA)
- Use the Northern Cross as **test-bed** for **wideband antenna feeding arrays** and **receiving systems (SKADS)**
- Upgrade of the E/W arm of Northern Cross Radio Telescope to a **LOFAR SuperStation** (from 2000 to 5000 m<sup>2</sup> of collecting area)
- **Long Baseline Interferometry Test**  
(Dwingeloo-Medicina)



# Northern Cross Radio Telescope

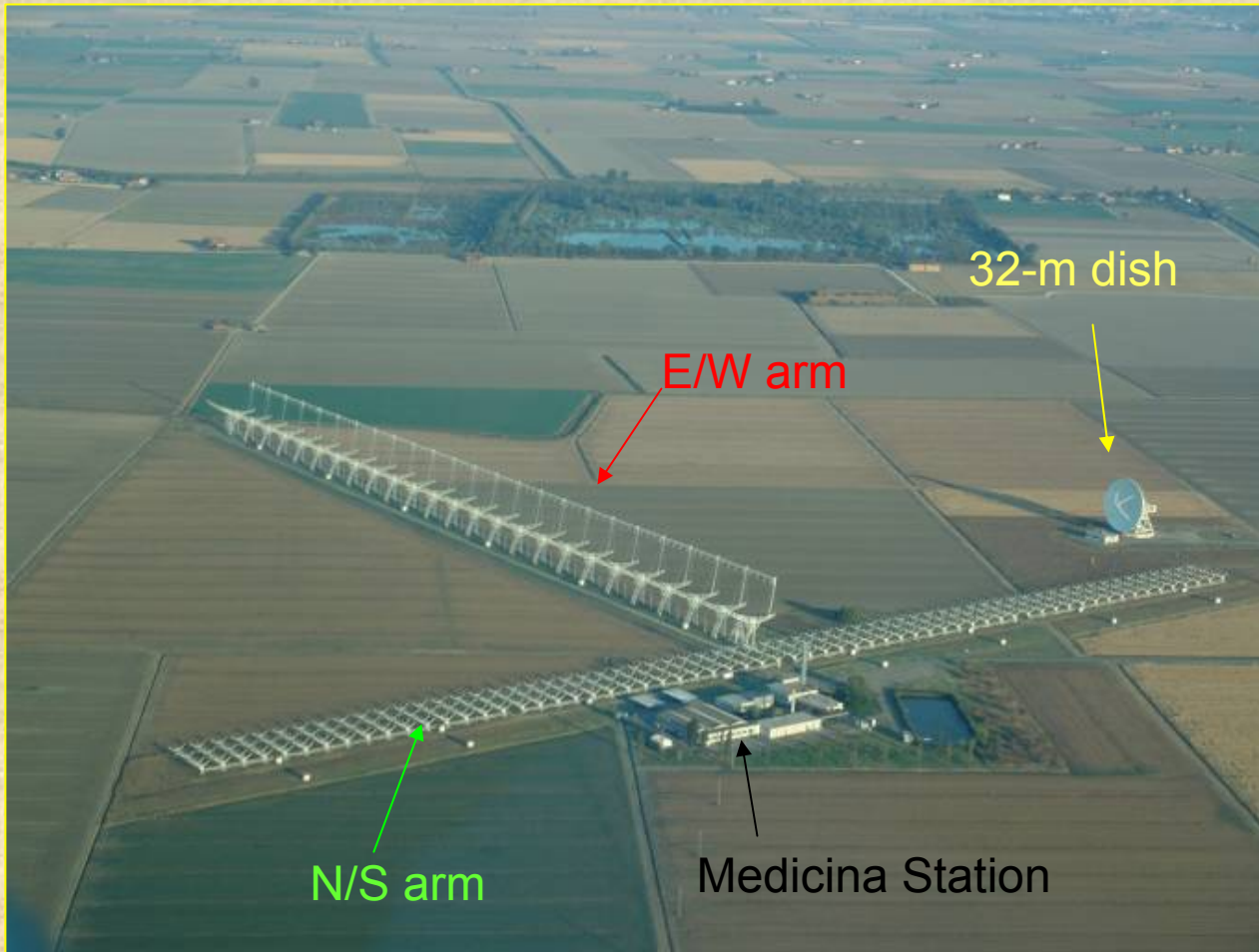

## **E/W arm**

Single reflector  
560 mt x 35 mt  
(1536 dipoles)

## **N/S arm**

Array of 64 reflectors  
640 mt x 23.5 mt  
(4096 dipoles)

**Collecting area:**  
**30000m<sup>2</sup>**

# Outline

- EM modeling and characterization of large cylindrical wired reflectors
- Design of three wideband feeding arrays for the LOFAR 120-240 MHz frequency band
  - Fat Dipole
  - Branched Vivaldi
  - Log-Periodic Array
- Conclusion



# EM modeling of wired cylindrical reflectors

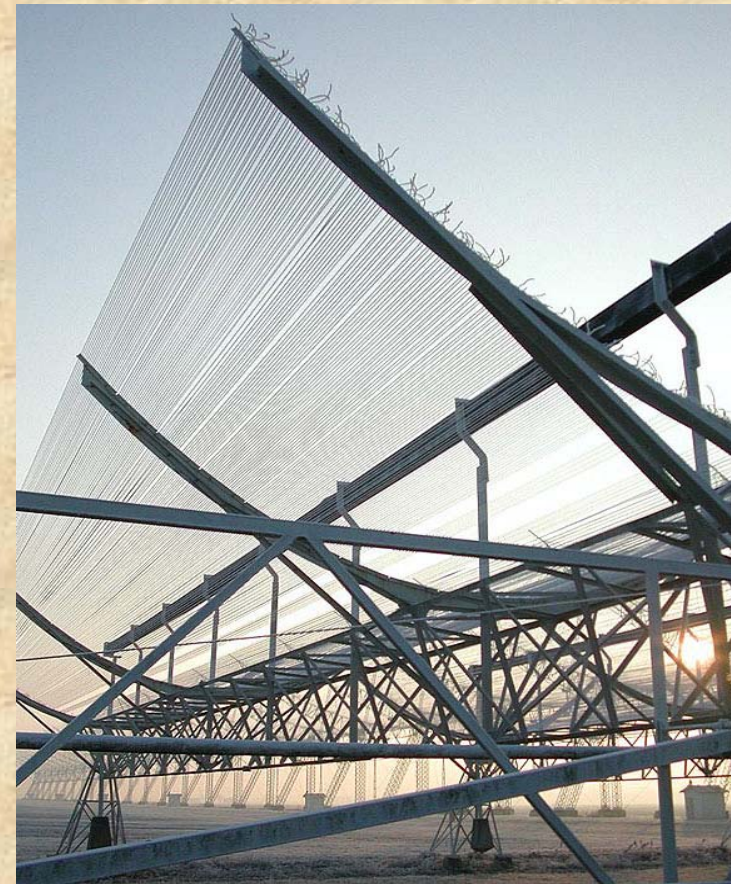

# 2D scattering from thin wires

## Equivalence Theorem

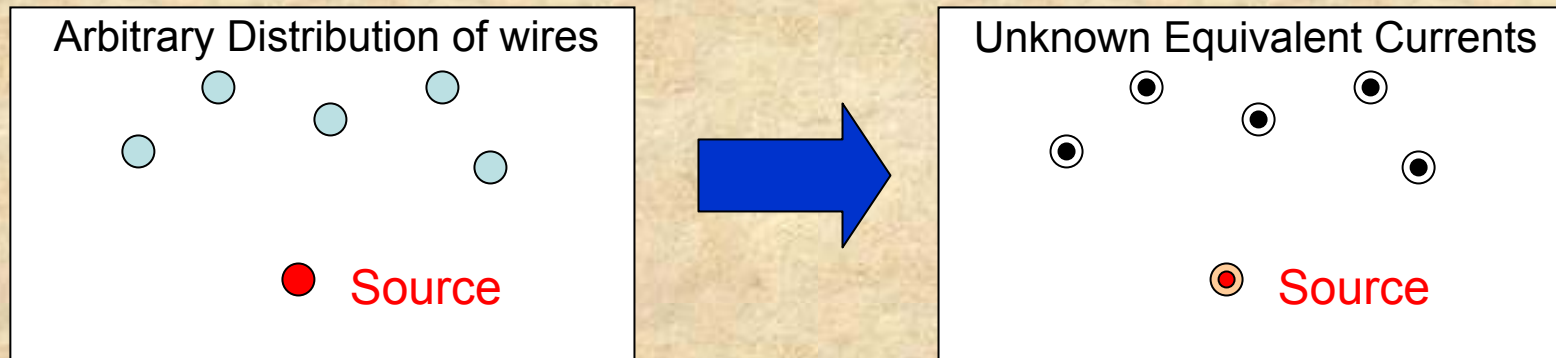

2D Green's function

$$E_i(\underline{\rho}) = -\frac{\omega\mu I_i}{4} H_0^{(2)}[K_0(\underline{\rho} - \underline{\rho}_i)]$$

Functional equation

(E-field boundary condition)

solved by method of moments

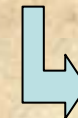

Induced current distribution



# N/S arm wired reflector

Wire Distribution Nwires=460

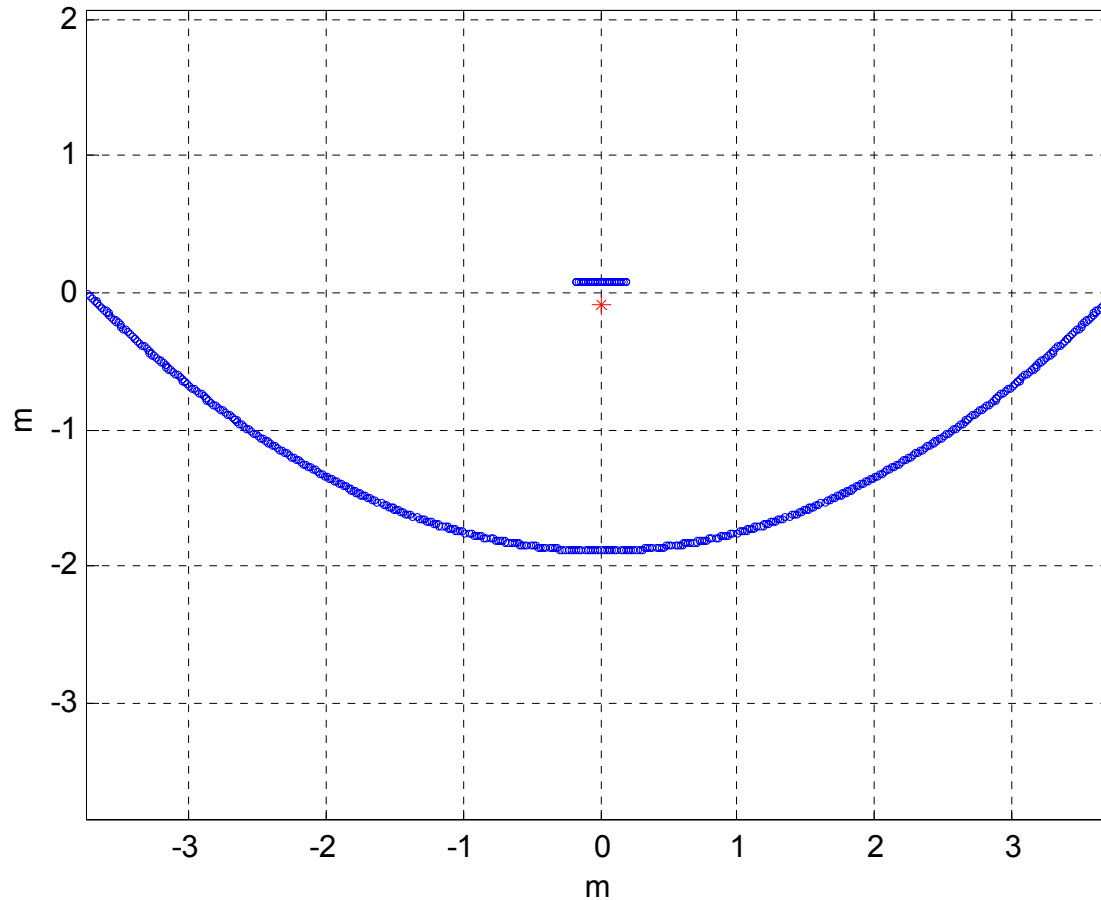

Focal length = 1.875 m

Aperture = 7.5 m

# H-plane radiation pattern @408 MHz

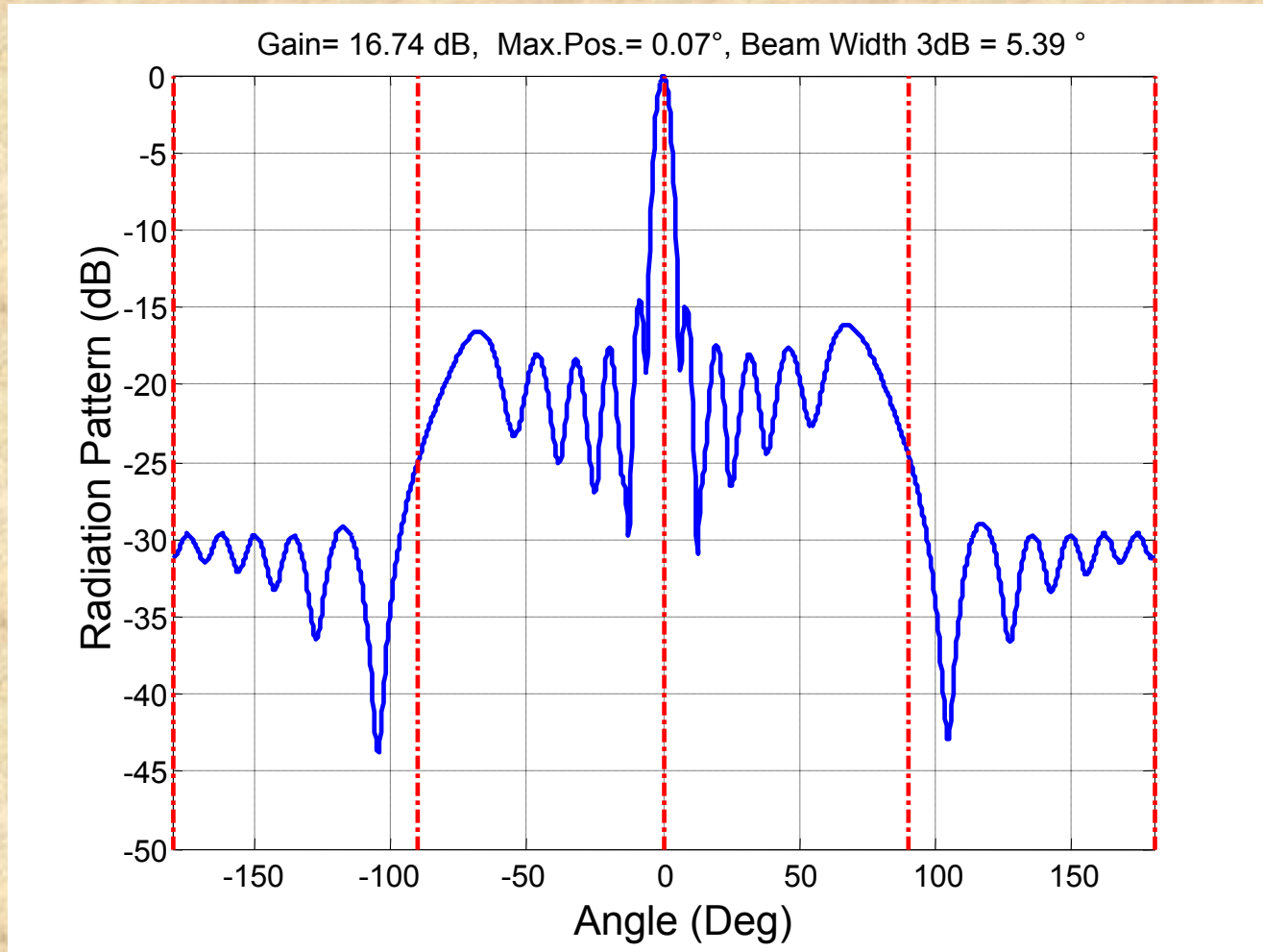

# Antenna Gain

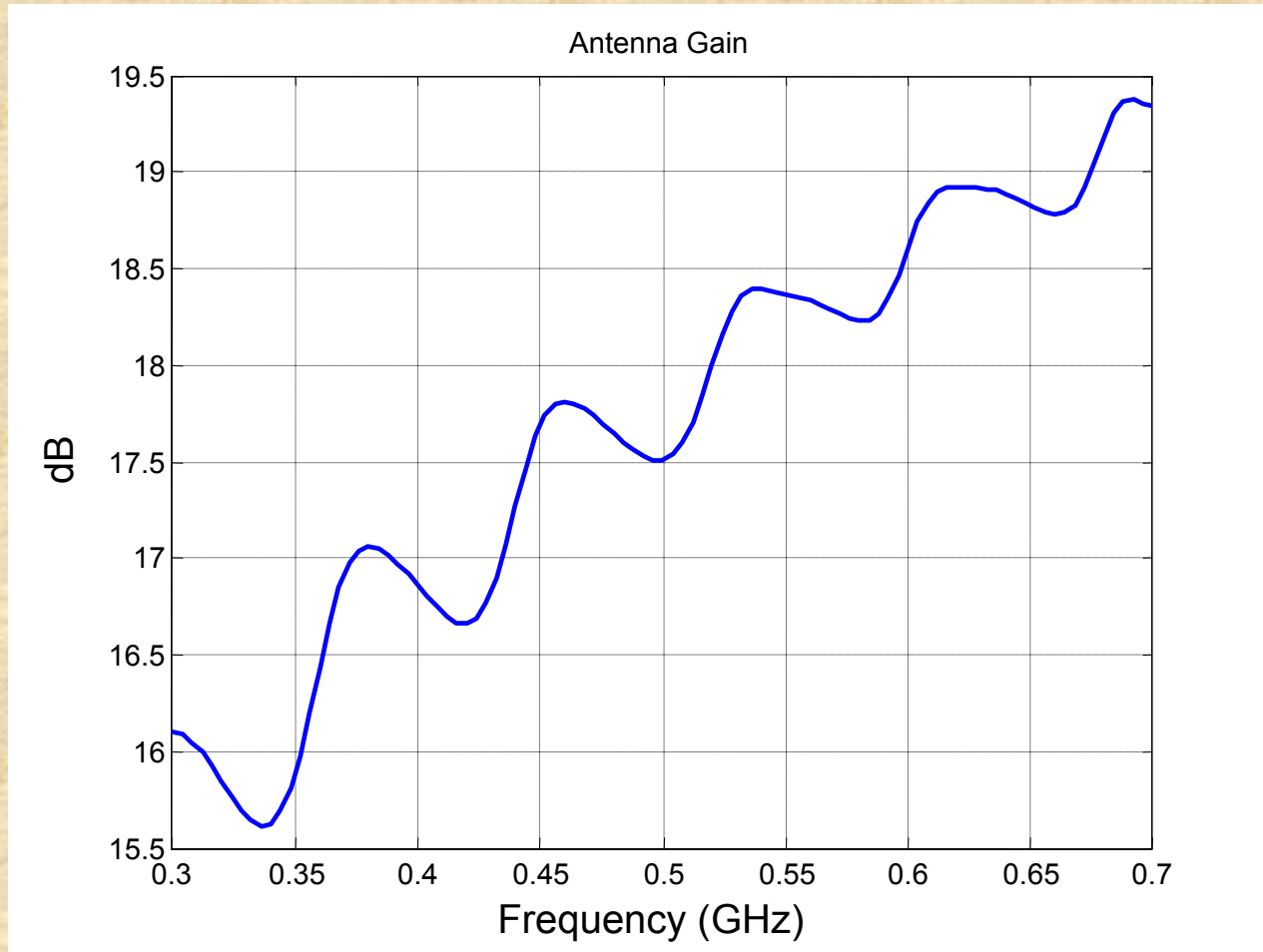

The ripple is due to the interaction between reflector and flat subreflector



# The E/W arm

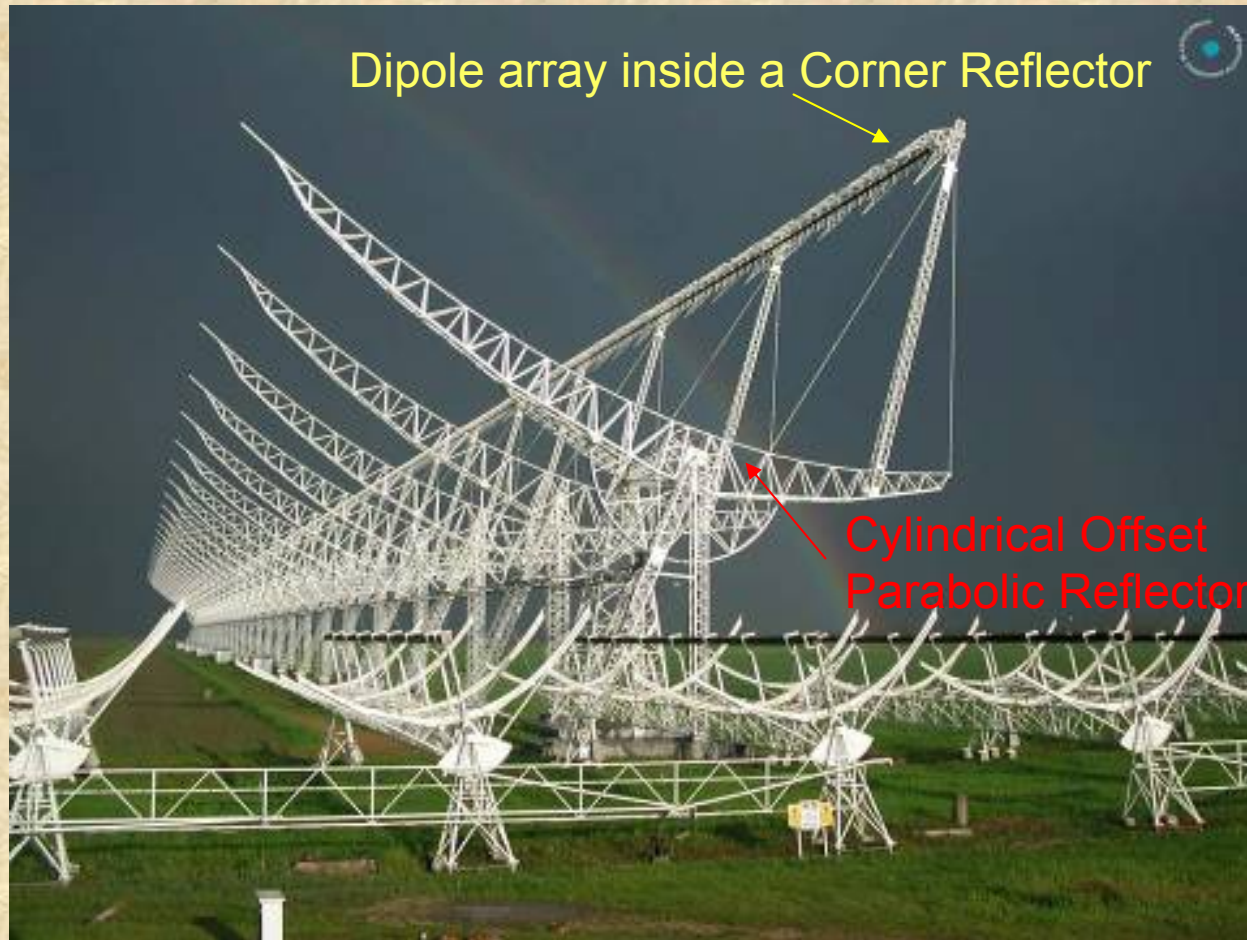

# E/W Arm Analysis in the present configuration @ 408 MHz

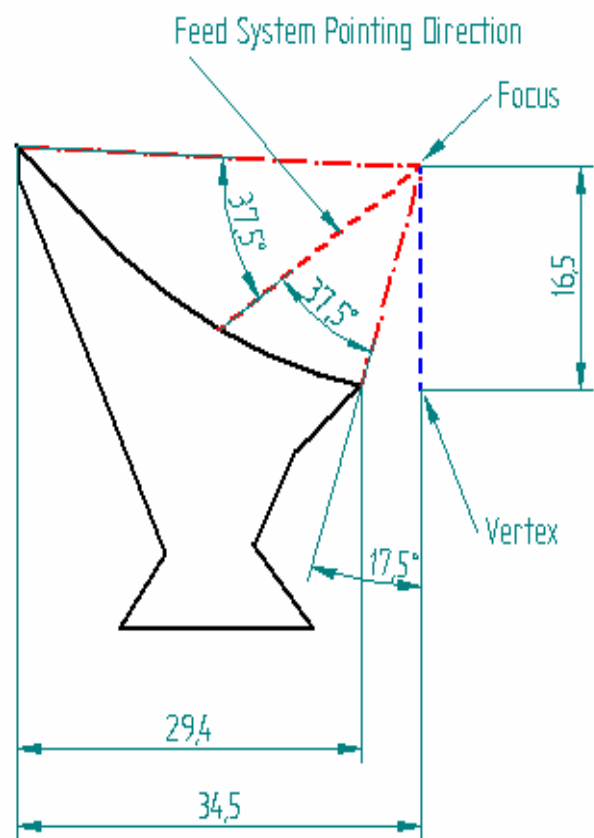

Wire distribution, N (number of wires)= 2037

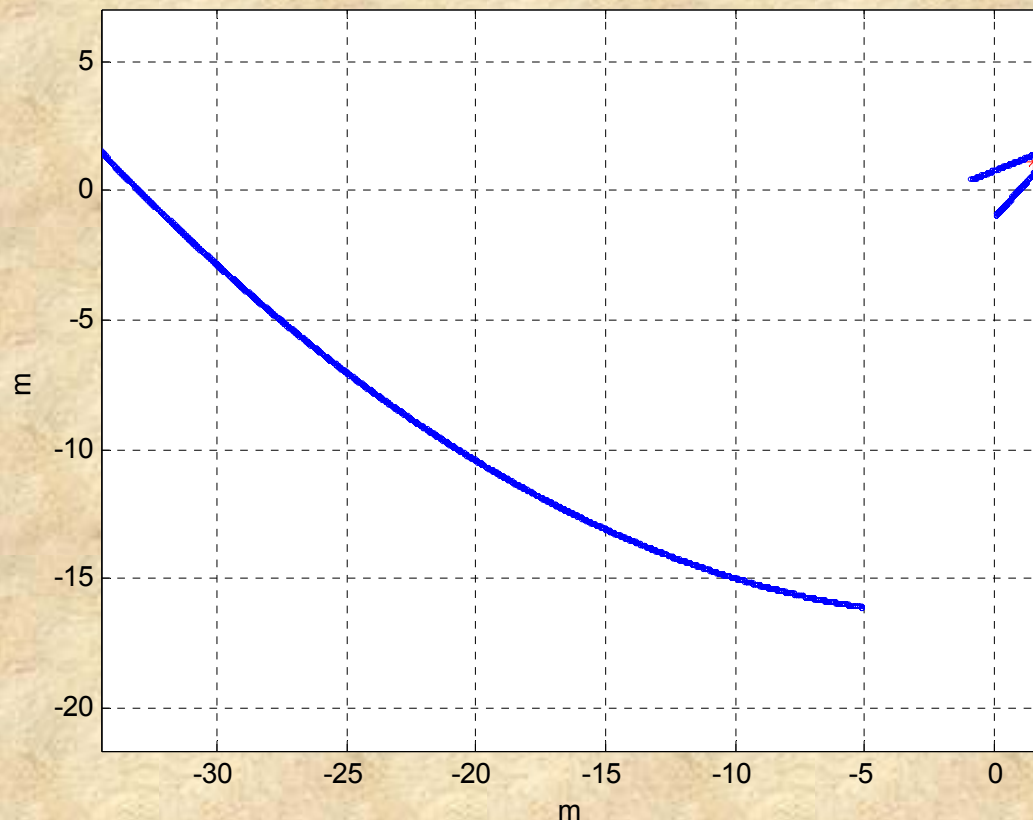

# E/W Arm Analysis in the present configuration @ 408 MHz

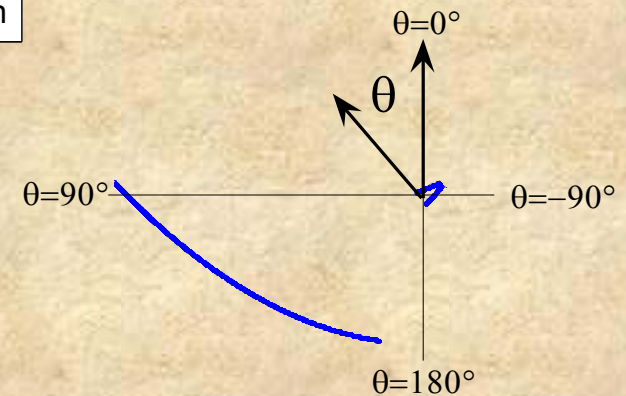
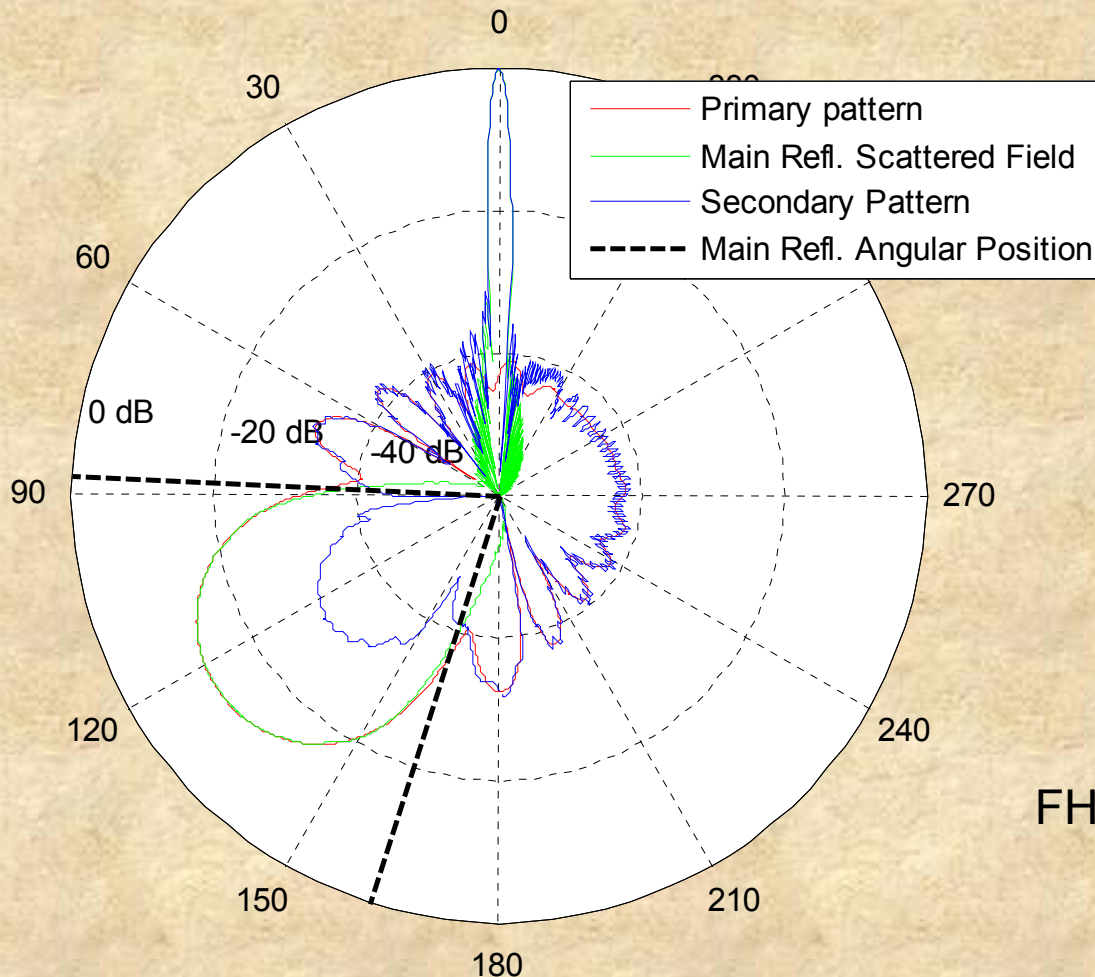

FHPBW is  $1.88^\circ$  in the H-plane



# Optimized E/W Arm @ 408 MHz

Wire distribution, N (number of wires)= 196

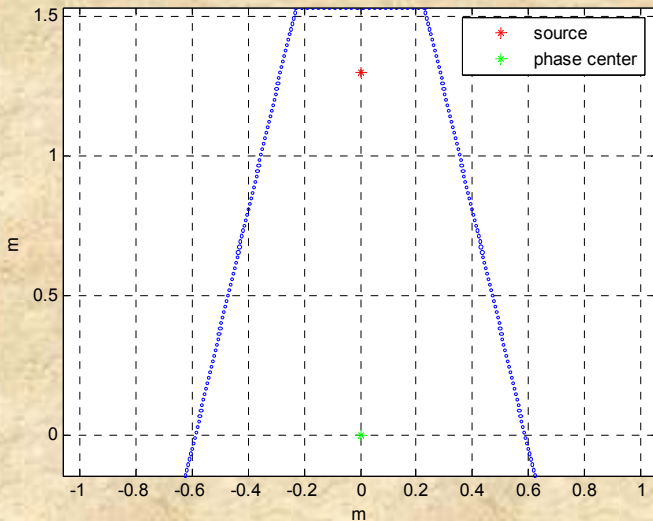

Max Directivity= 23.28 dB, Max.Pos.= 0.01°, FHPBW = 1.54 °

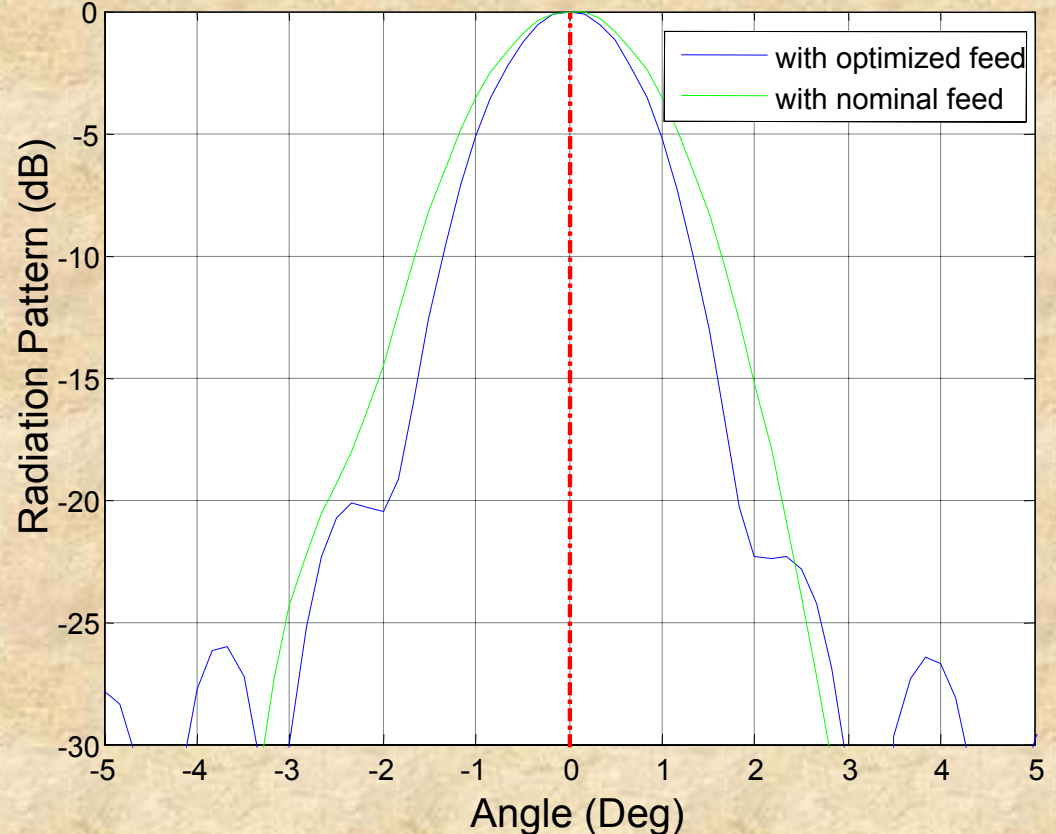

Optimized Subreflector  
(The Aperture is 74% with respect to the present 1.69 m)

efficiency enhancement from  $\eta=0.70$  to  $\eta =0.85$



# Fat dipoles

## “sparse array” solution

### 120-240 MHz

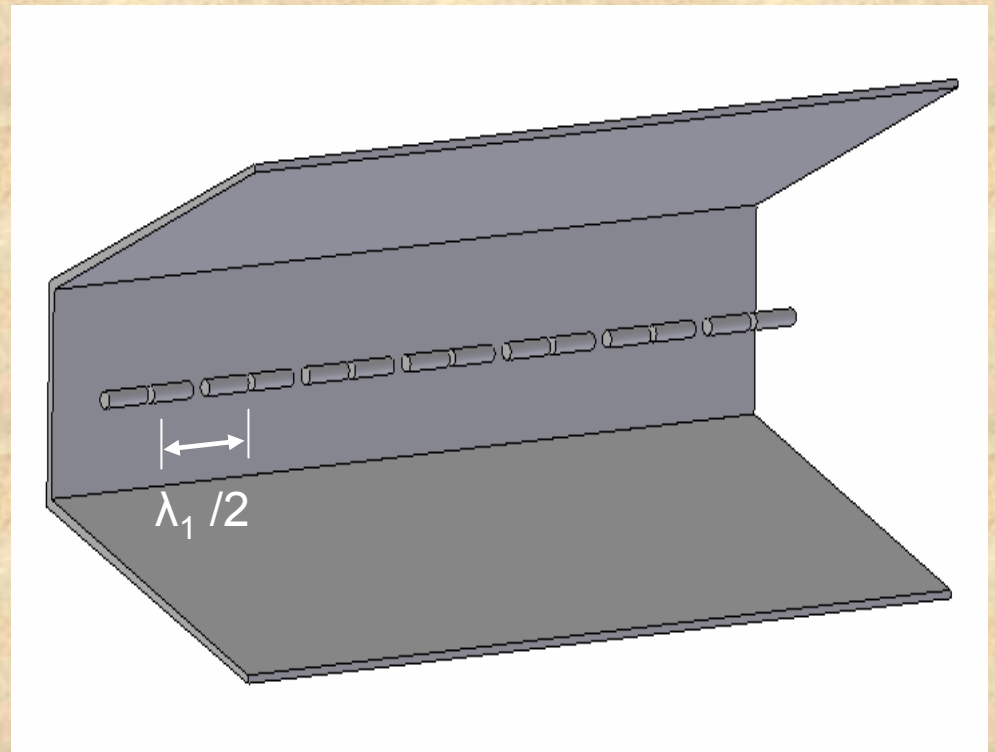

# Fat Dipole Array Design

LOFAR 120÷240 MHz  $\rightarrow \lambda_1=2.5$  m

2D DESIGN

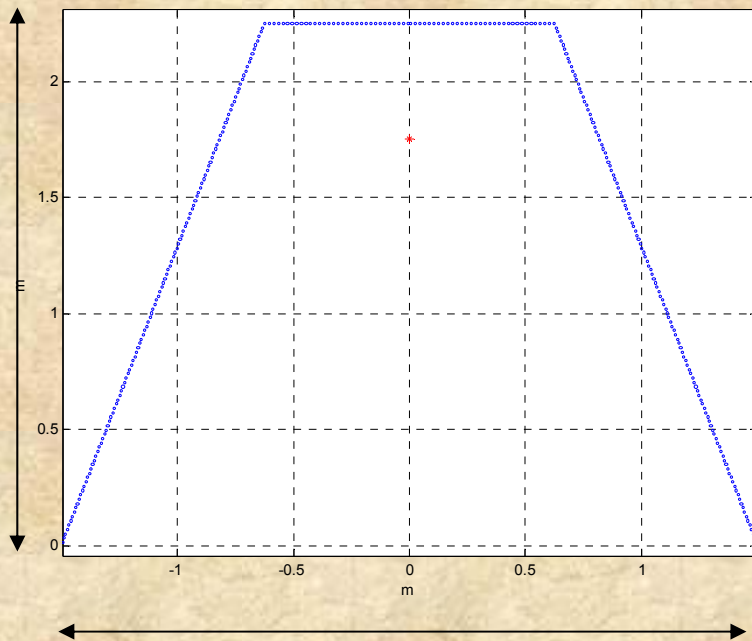

$$W = 3 \text{ m} = 1.2 \lambda_1$$

3D DESIGN

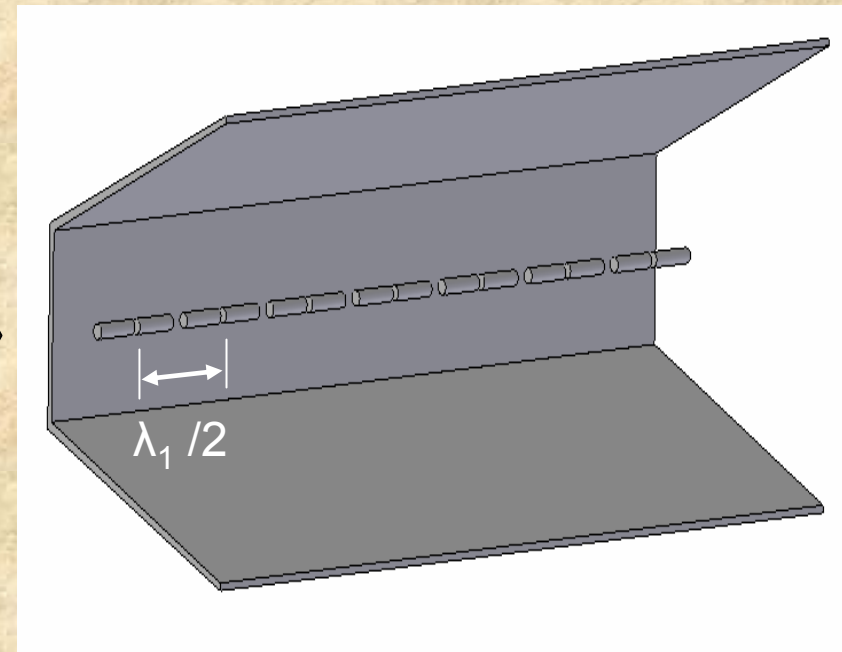

- The inter-element spacing is  $\lambda_1 / 2 = 1.25$  m
- The dipole length  $L = 0.42 \lambda_1 = 1.05$  m
- The dipole diameter is  $0.1L = 105$  mm



# Reflection and coupling coeff.

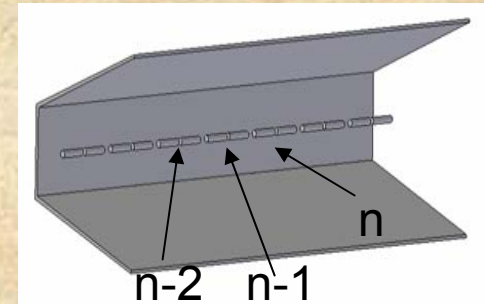
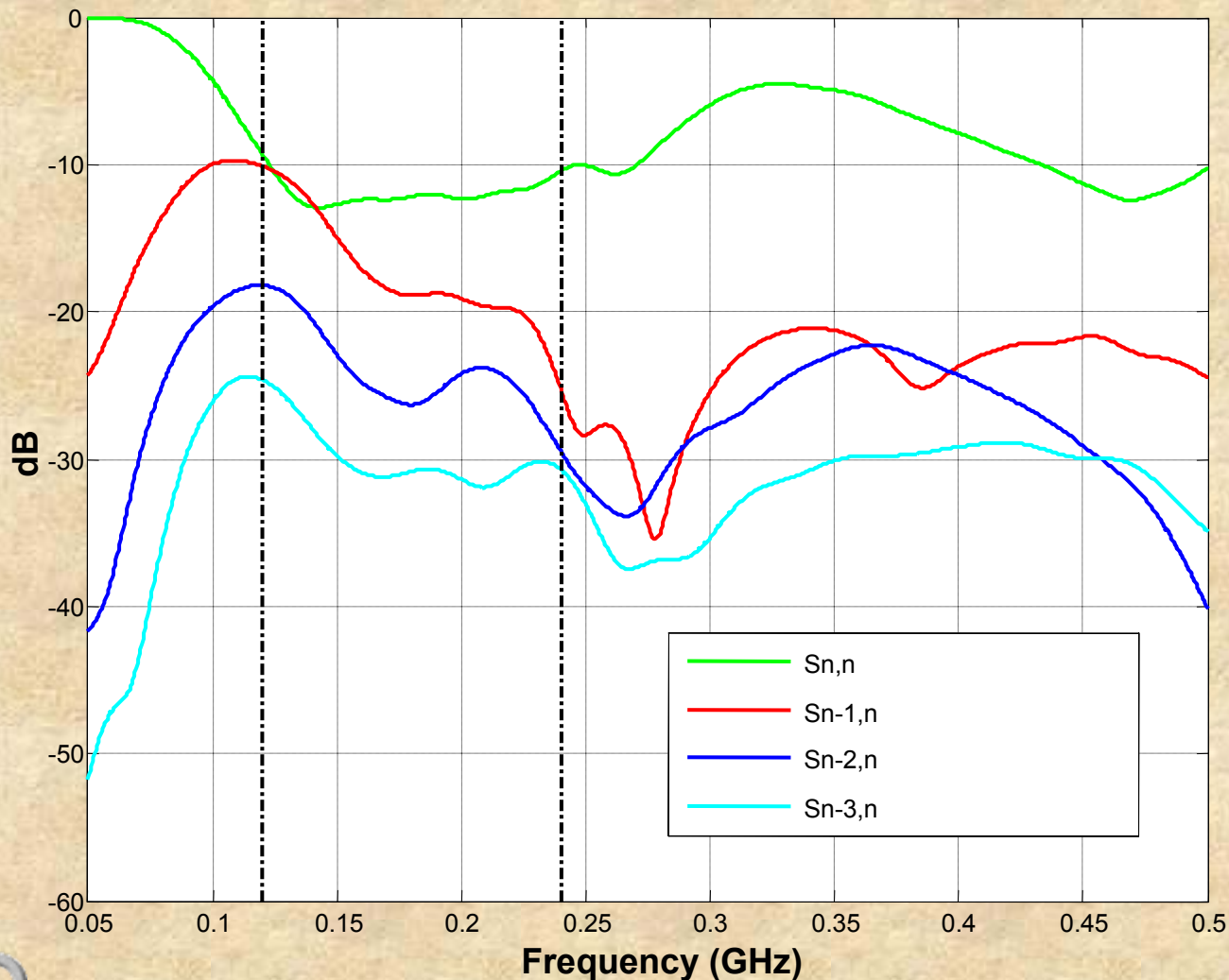

# E/W Arm @ 120÷240 MHz

Wire distribution, N (number of wires)= 2049



Fat dipoles  
+  
Subreflector



# E/W Arm @ 120 MHz

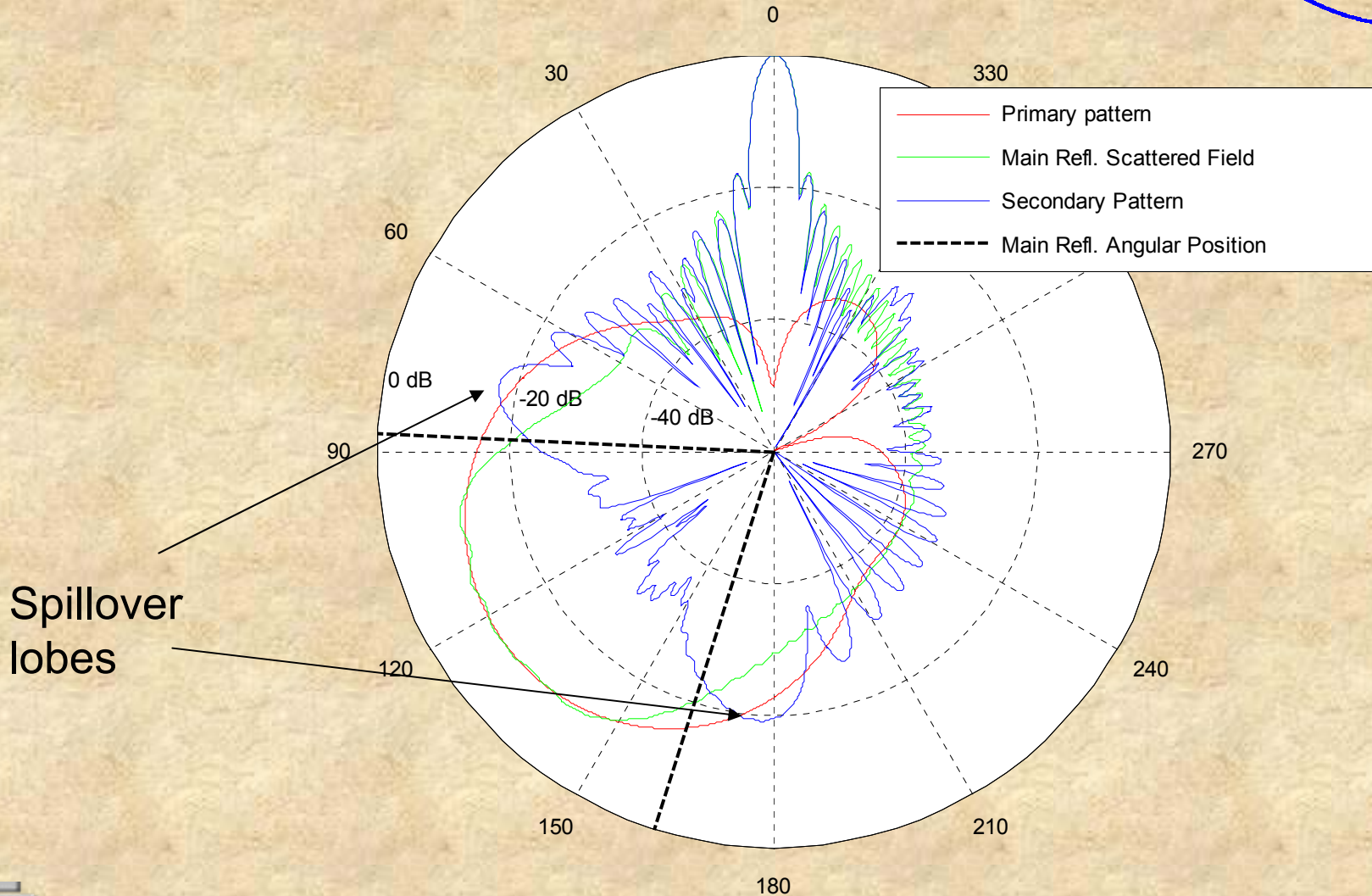
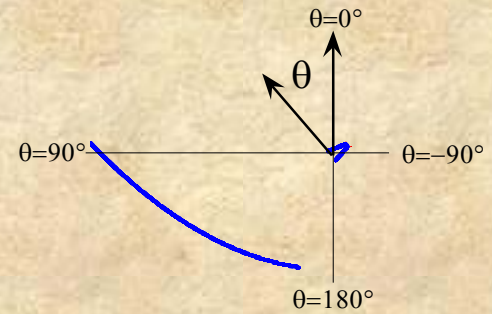

# E/W Arm @ 240 MHz

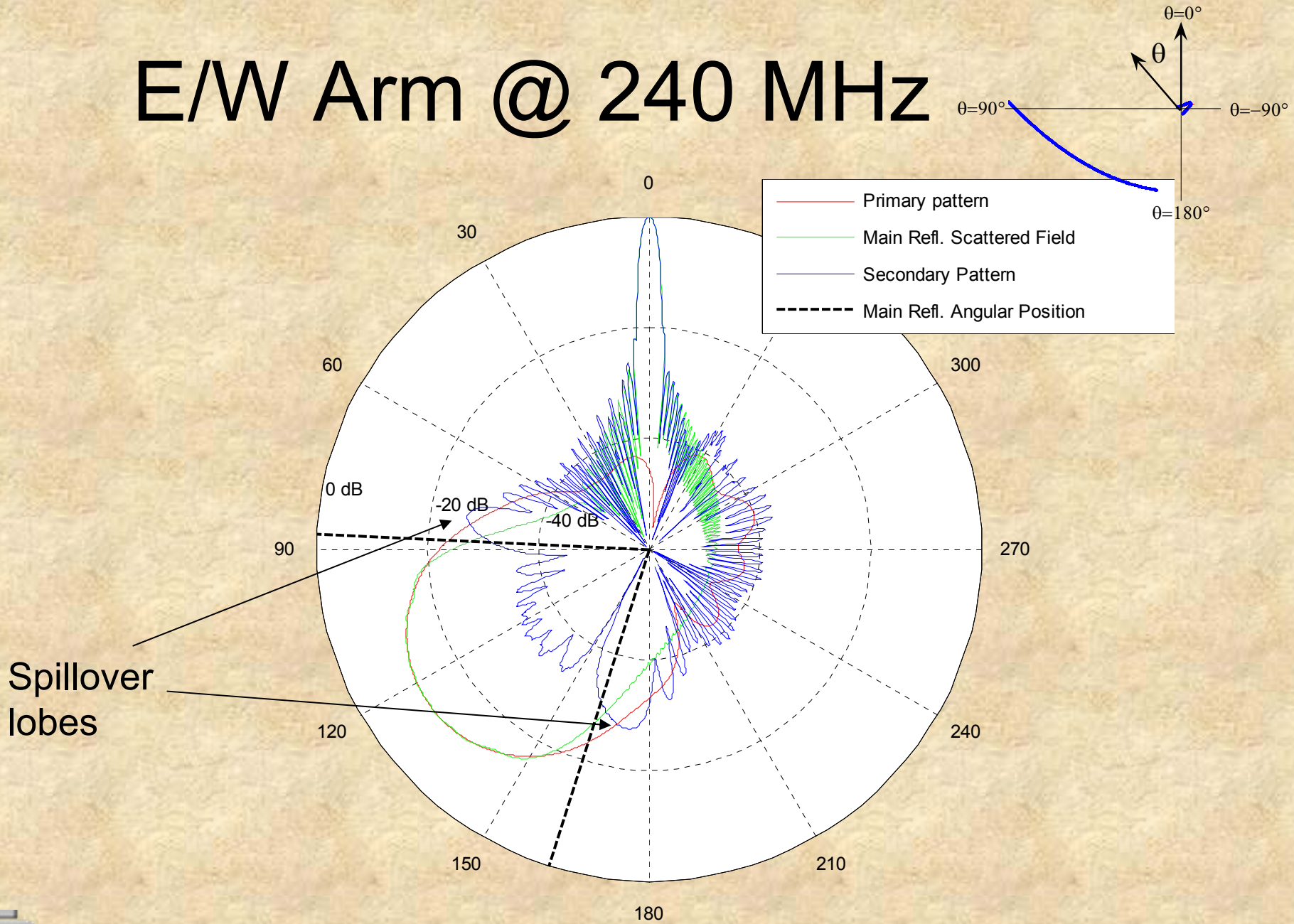

# FHPBW of the E/W Arm

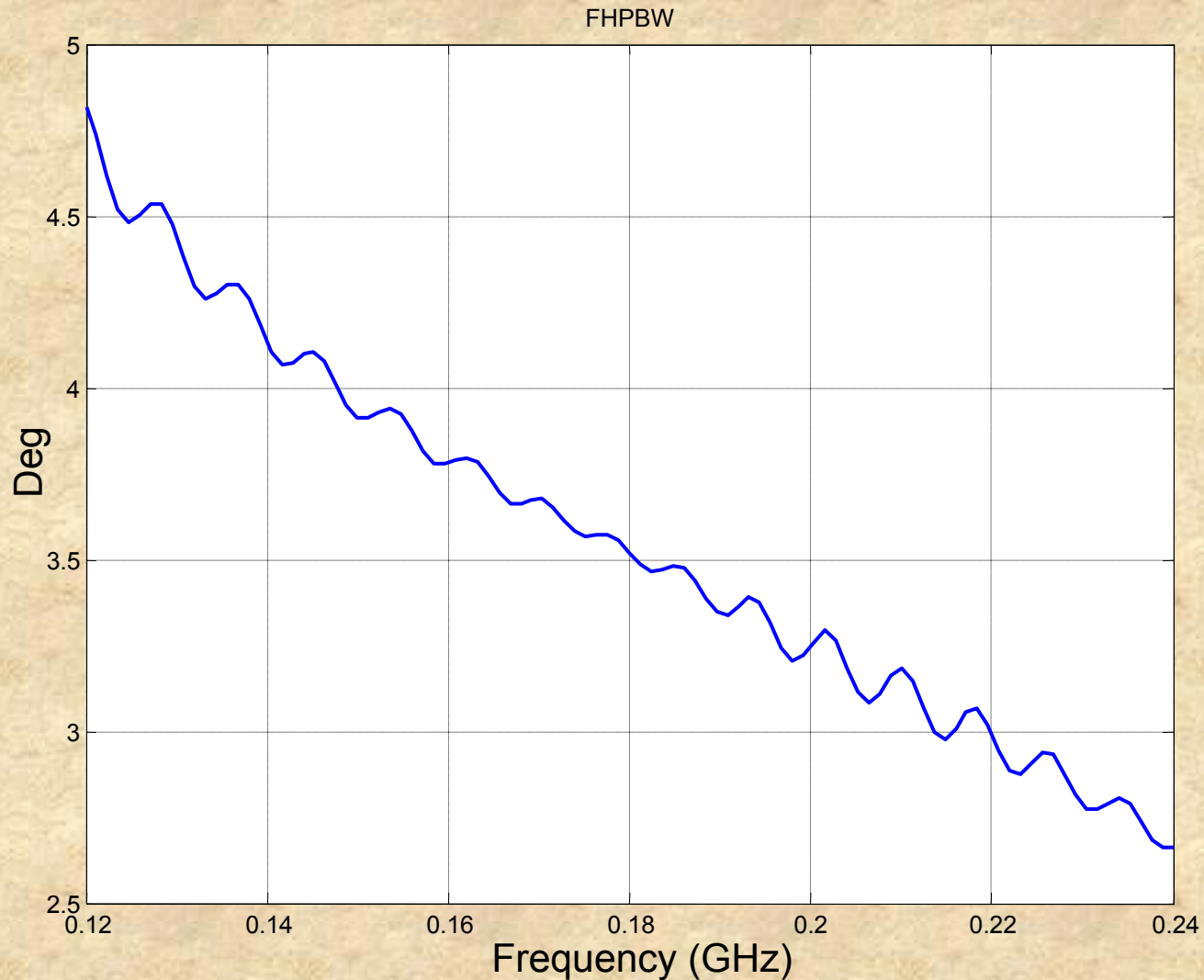

# Antenna efficiency

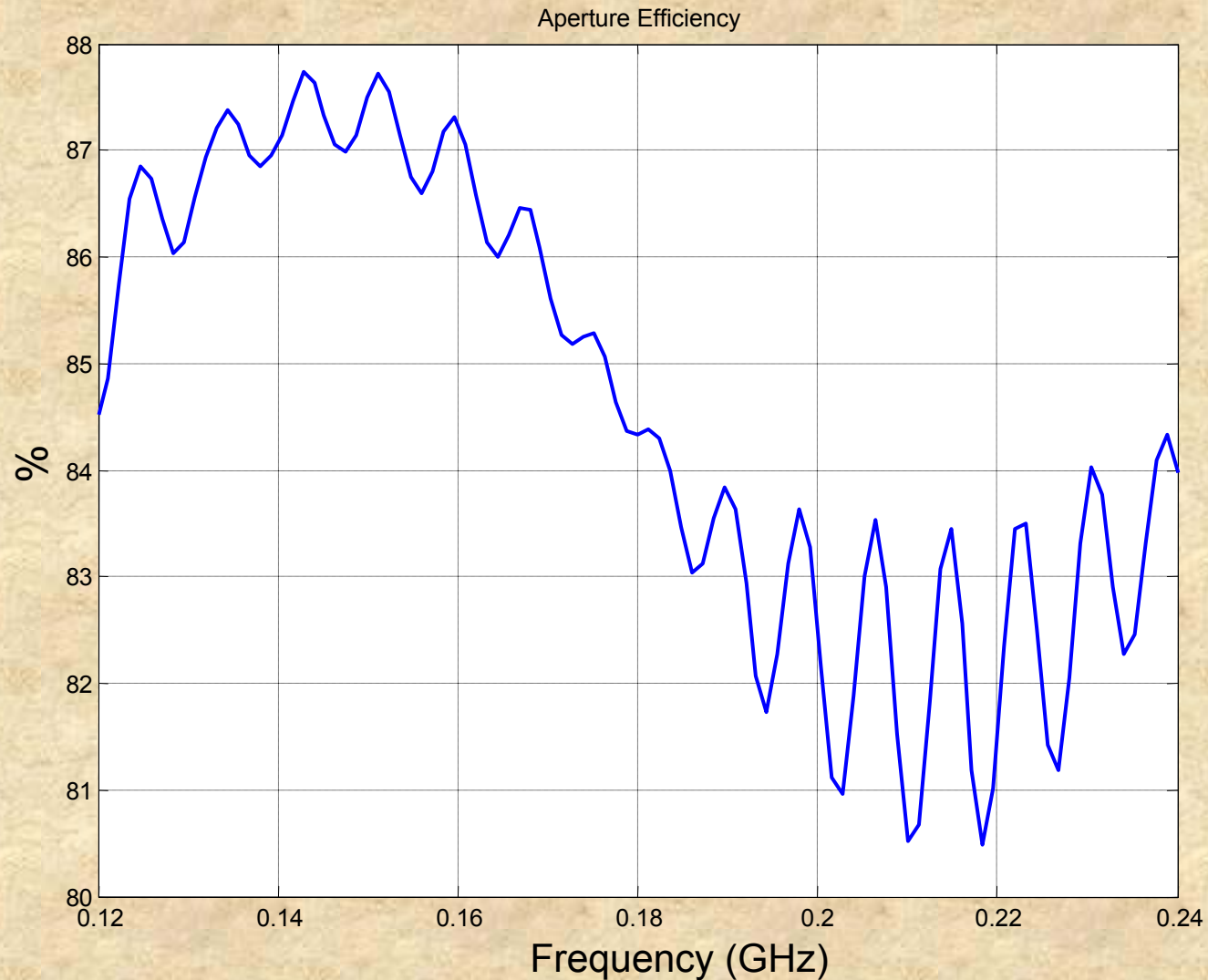

# Branched Vivaldi “dense array” solution

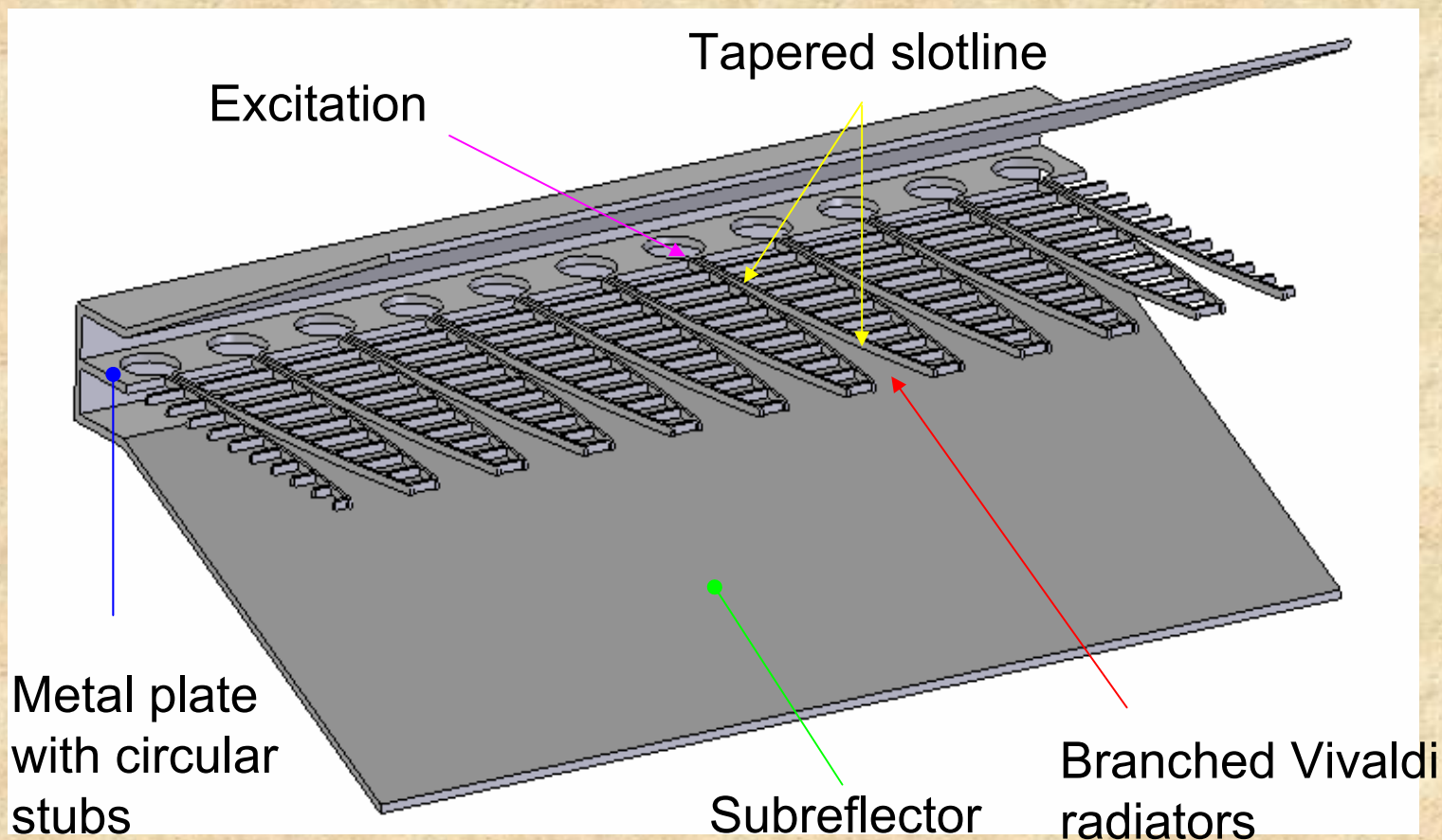

# Branched Vivaldi

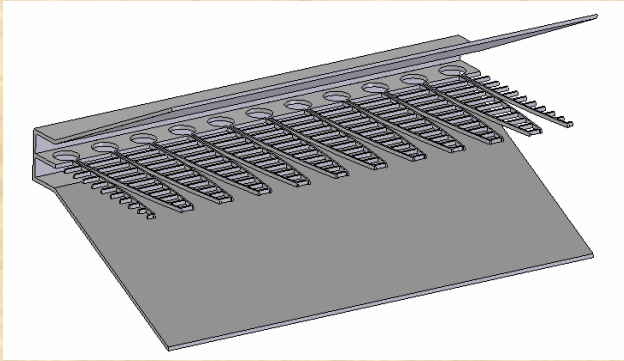

$$W = 3 \text{ m} = 1.2 \lambda_1$$

$$L = 2.9 \text{ m} = 7/6 \lambda_1$$

$$D = 0.56 \text{ m} = \lambda_1/4.5$$

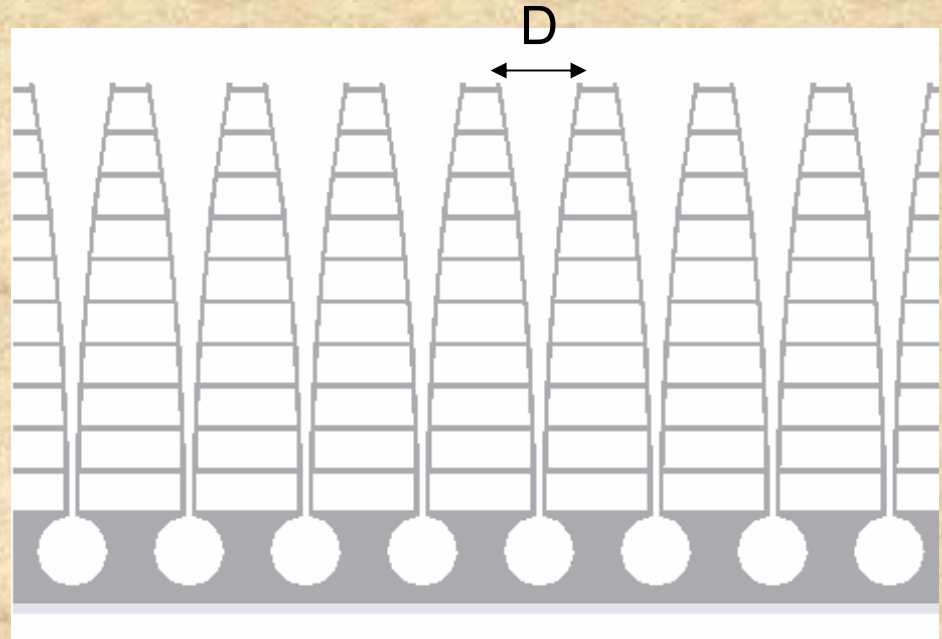
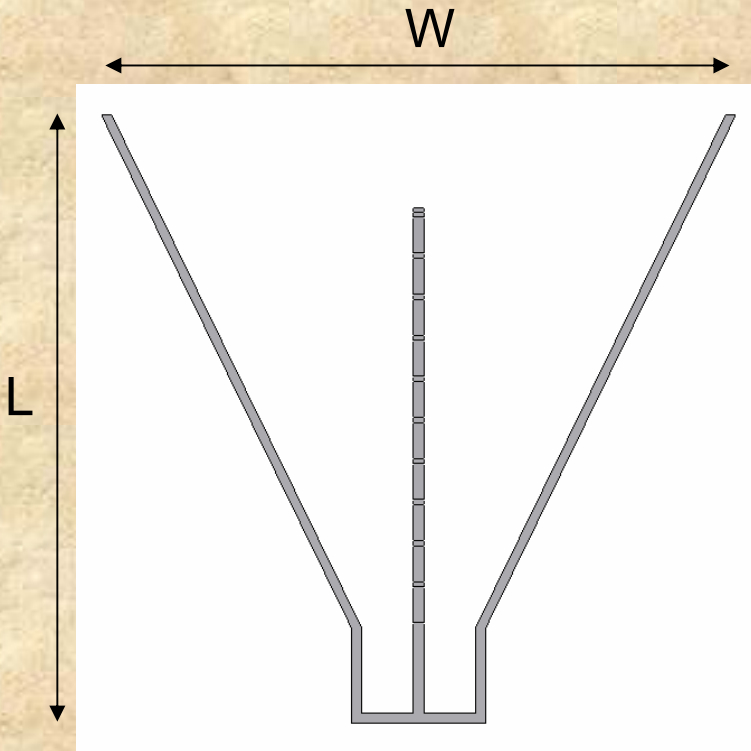

# Reflection coefficient

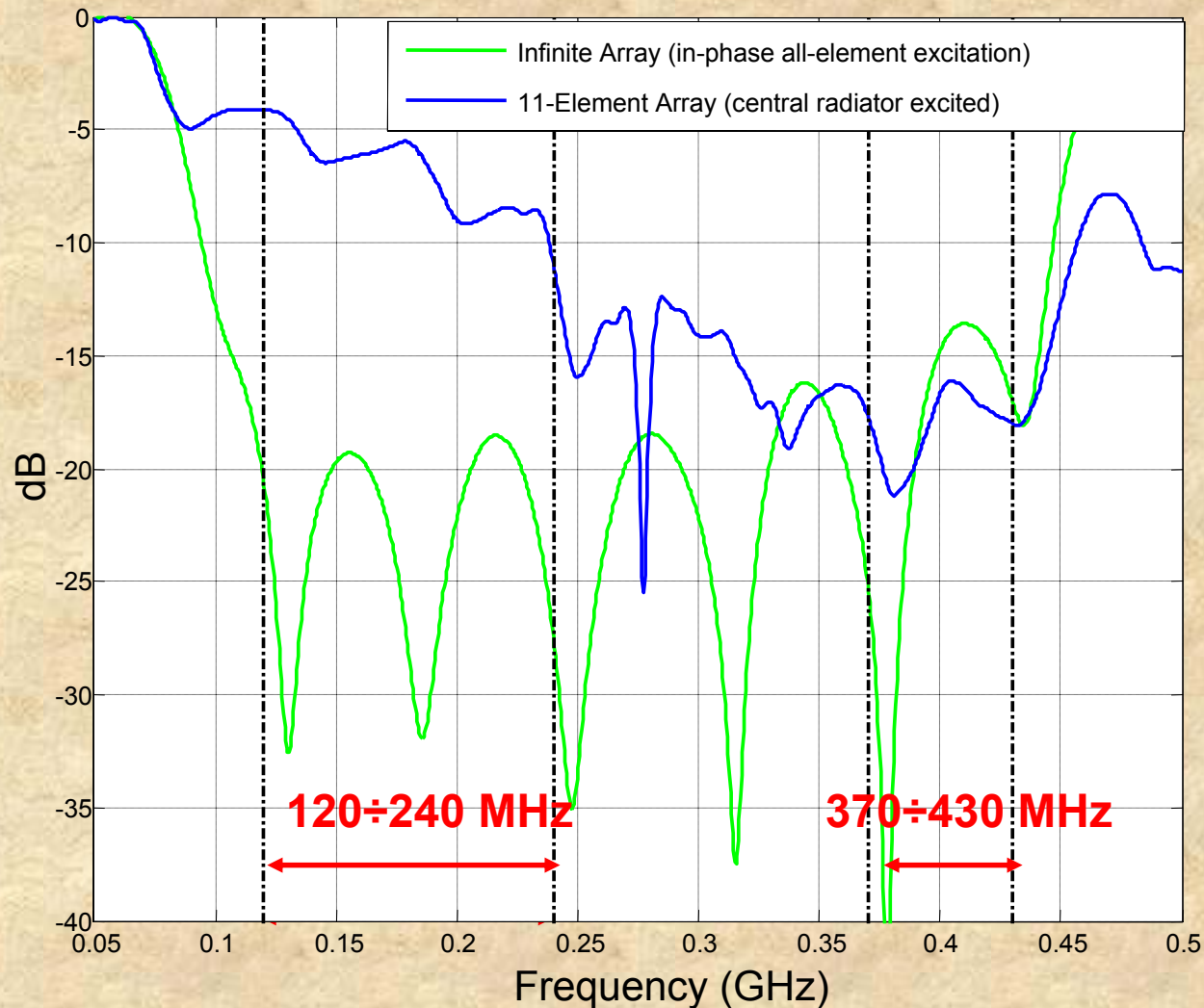

# Reflection and Coupling Coeff.

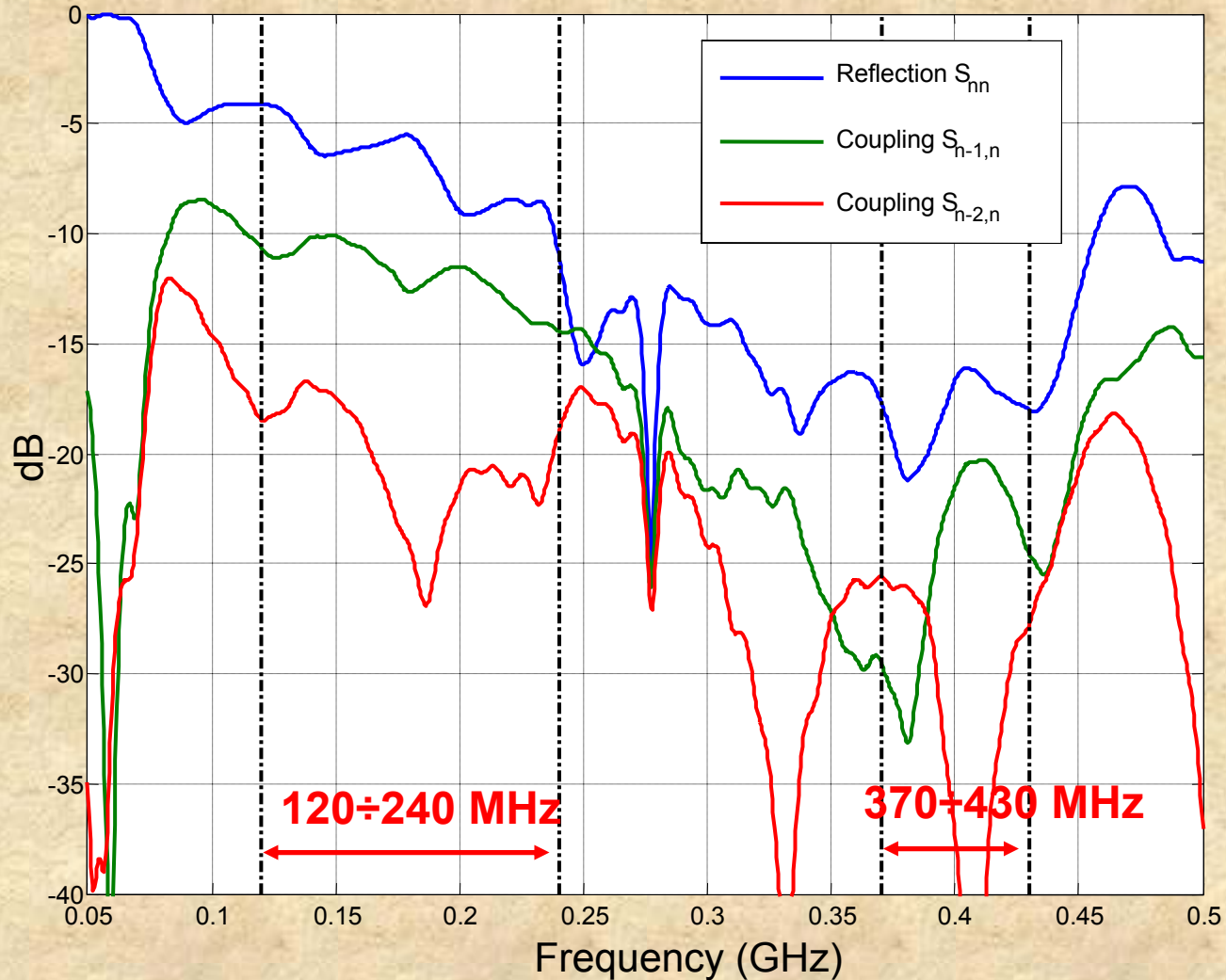

# Log-Periodic Antenna Array:

a simpler solution for a Long Base Interferometry Test

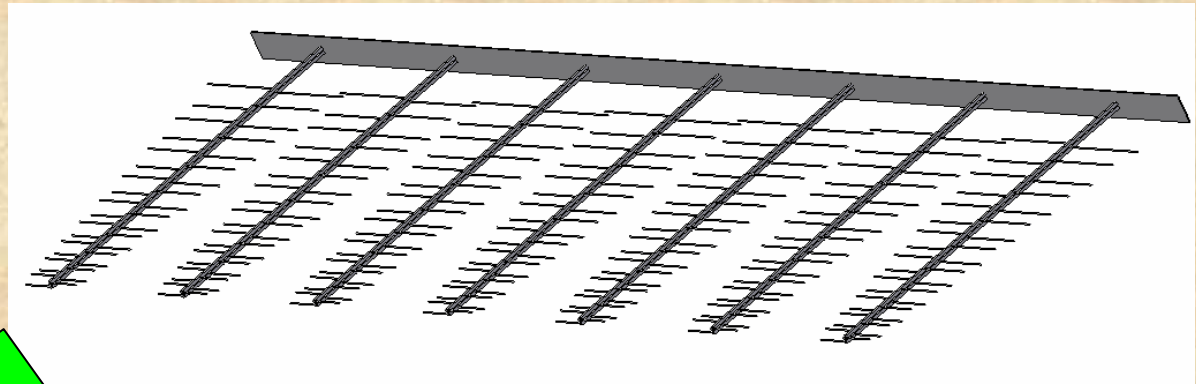

No Corner reflector but edge taper will be only 3dB

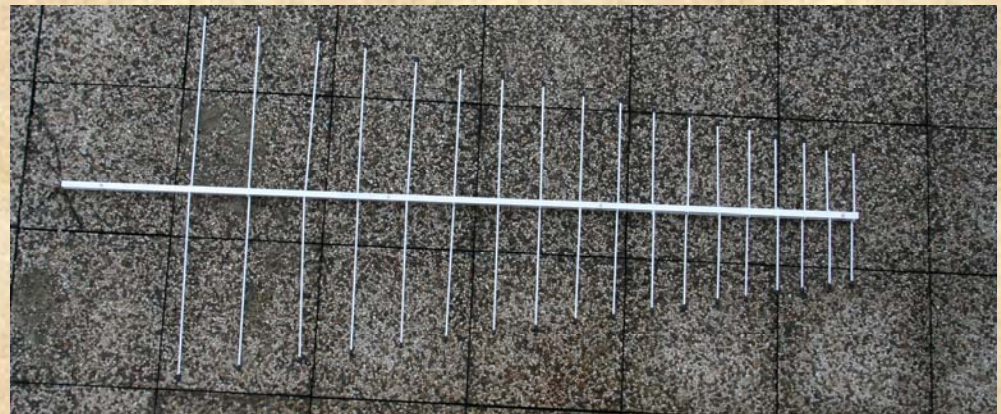

# Reflection and coupling coeff.

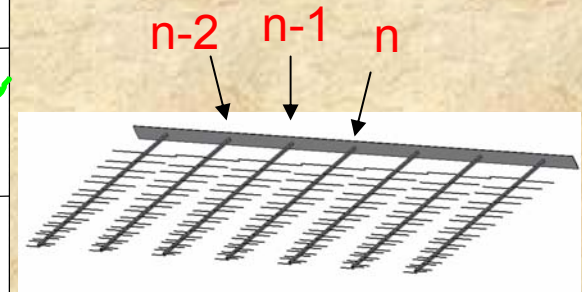
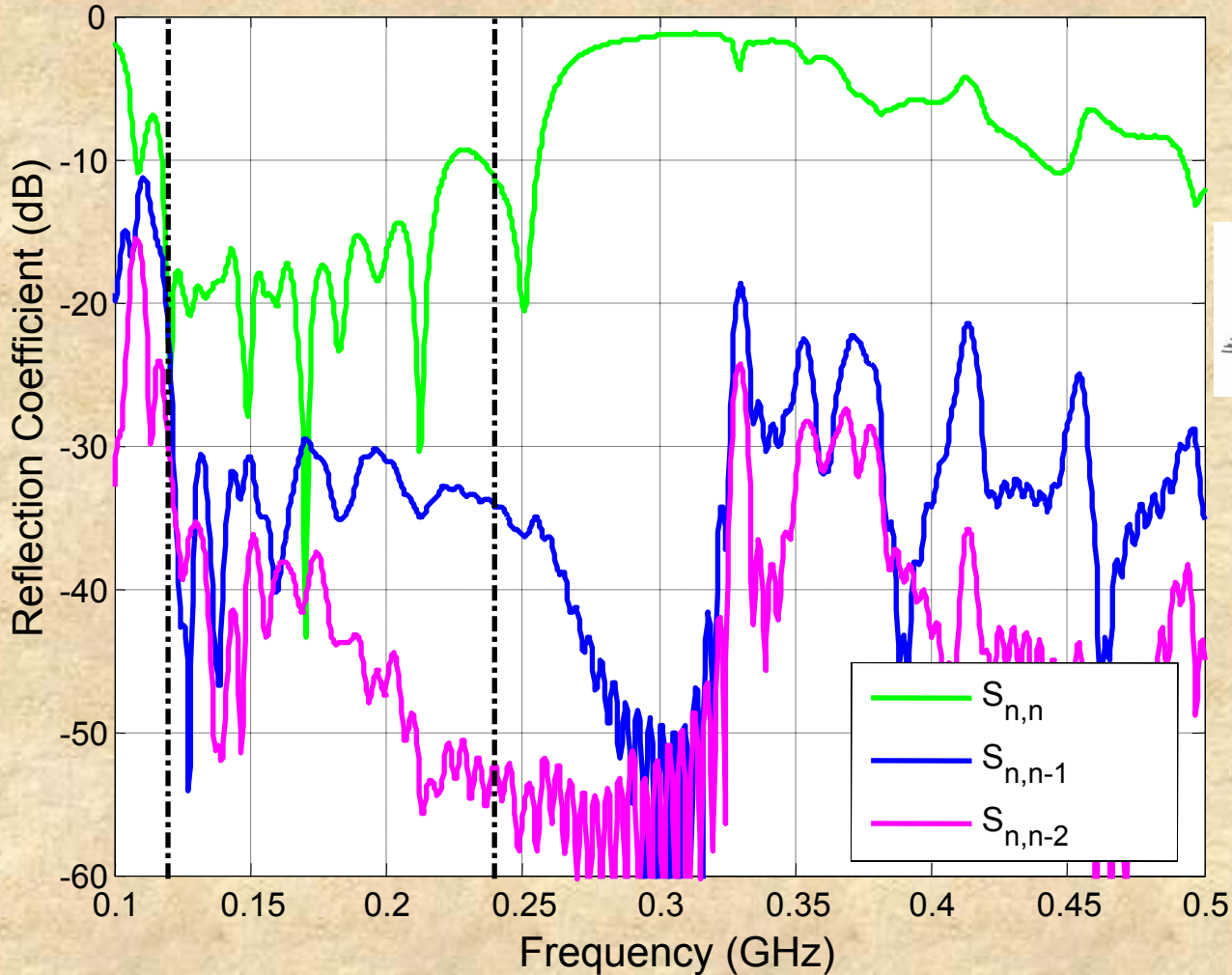

# H-plane pattern @ 120 MHz

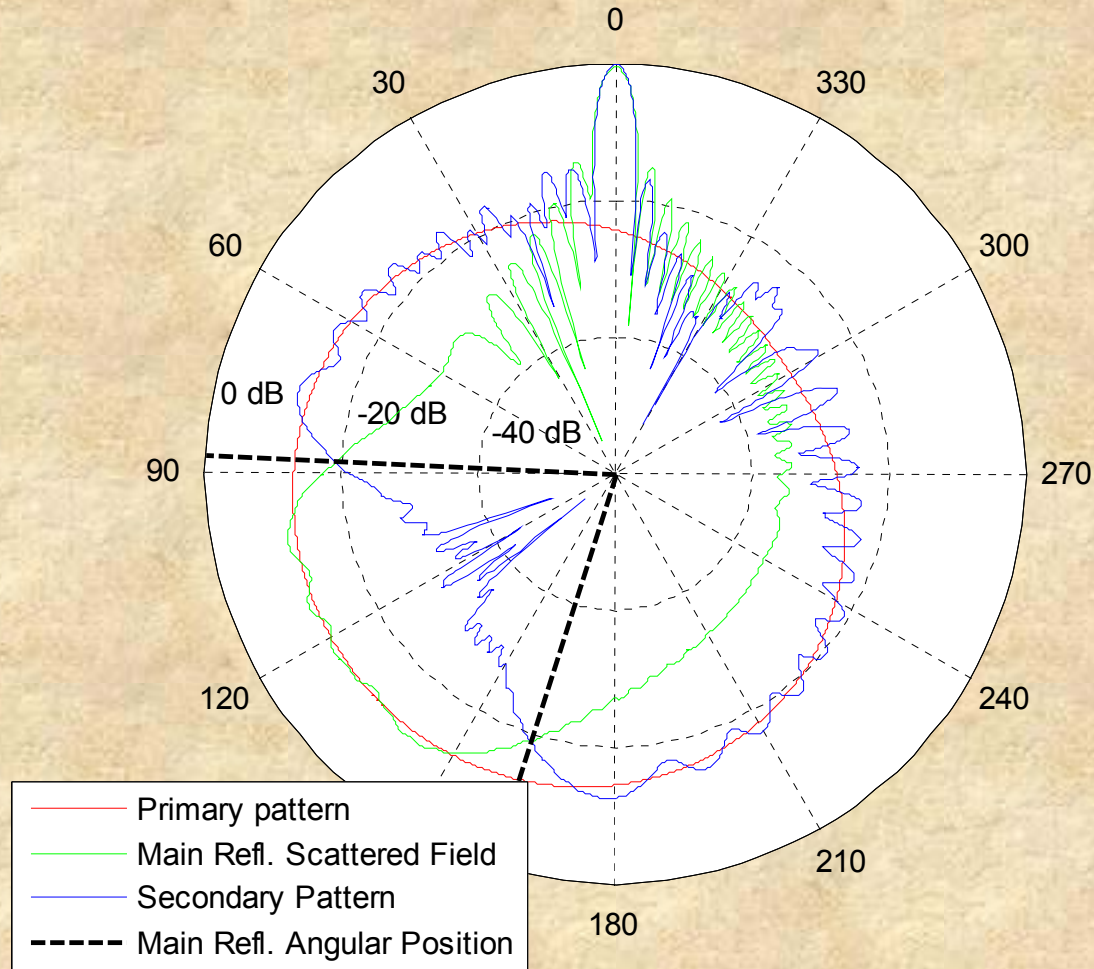

# H-plane pattern @ 240 MHz

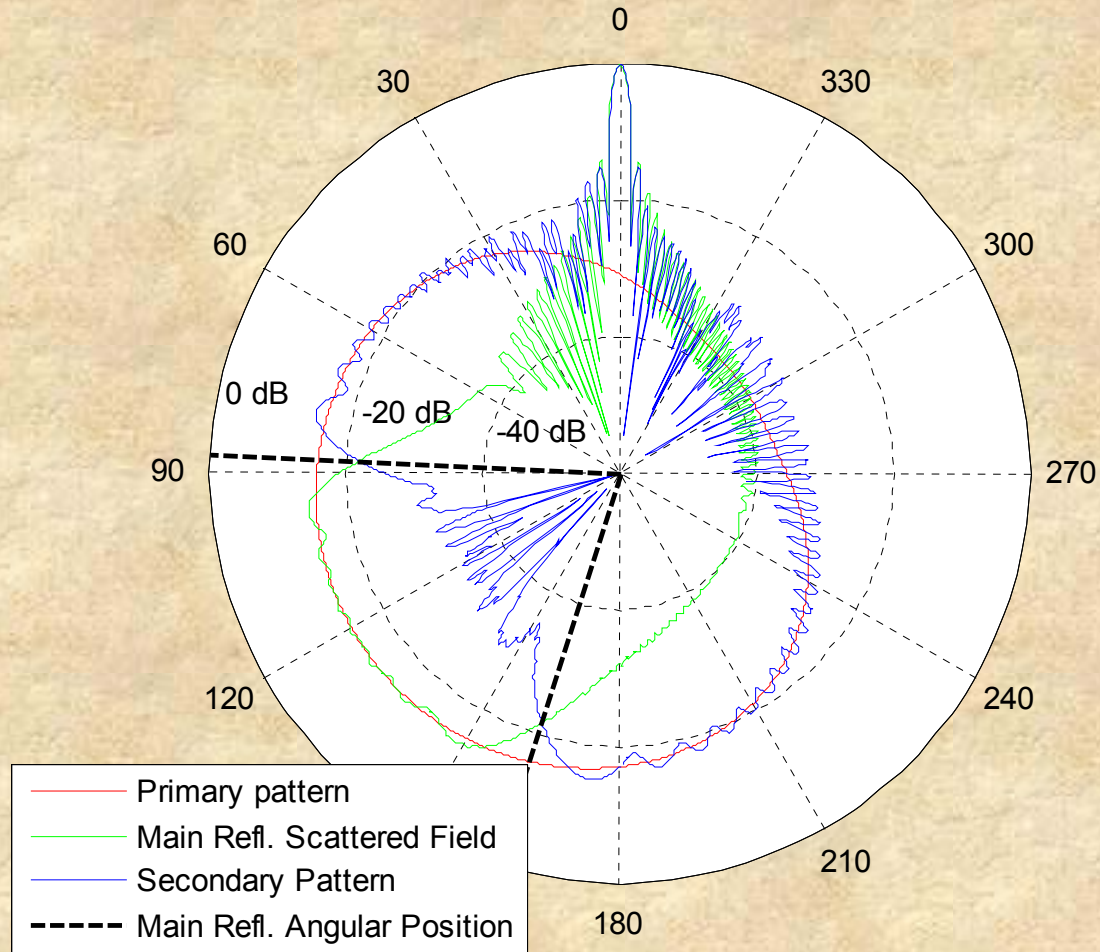

# Conclusion Table

	LOFAR 120÷240 MHz	408 MHz	Min. Return Loss (dB)	Grating Lobes (E-plane)	FoW (E-plane)	Efficiency (H-plane)
Present config.	NO	YES	--	--	--	70%
Optimized subreflector	NO	YES	--	--	--	85%
Fat dipole solution	YES	NO	9	YES	$\pm 30^\circ$	>80%
Branched Vivaldi solution	YES	YES	4	NO	$\pm 20^\circ$	>80%
Custom LPDA	YES	NO	9	YES	$\pm 30^\circ$	>65%



# Future Development

Focal plane array on the N/S arm

