

LOFAR: the LOw Frequency ARray

Radio Observatory and R&D divisions
ASTRON, Dwingeloo, The Netherlands

LOFAR data school 2018

LOFAR: Lots Of Flimsy Antenna Rigs

Radio Observatory and R&D divisions
ASTRON, Dwingeloo, The Netherlands

LOFAR data school 2018

- 1 Architecture
- 2 Stations
- 3 SHORT BREAK
- 4 Central processing
- 5 Beams, beams, beams...
- 6 More beams...
- 7 If all goes well

A BIG radio telescope

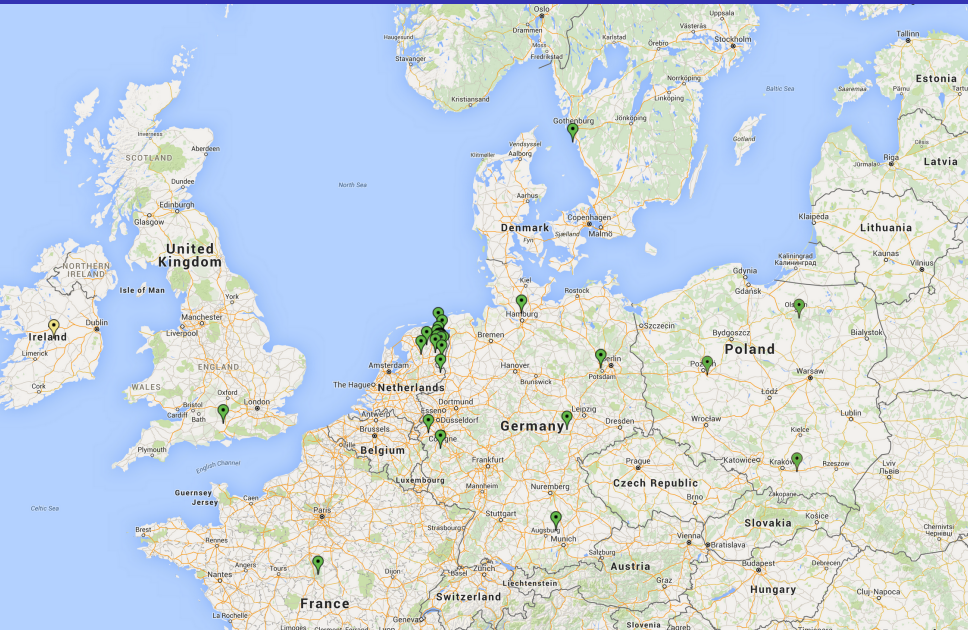

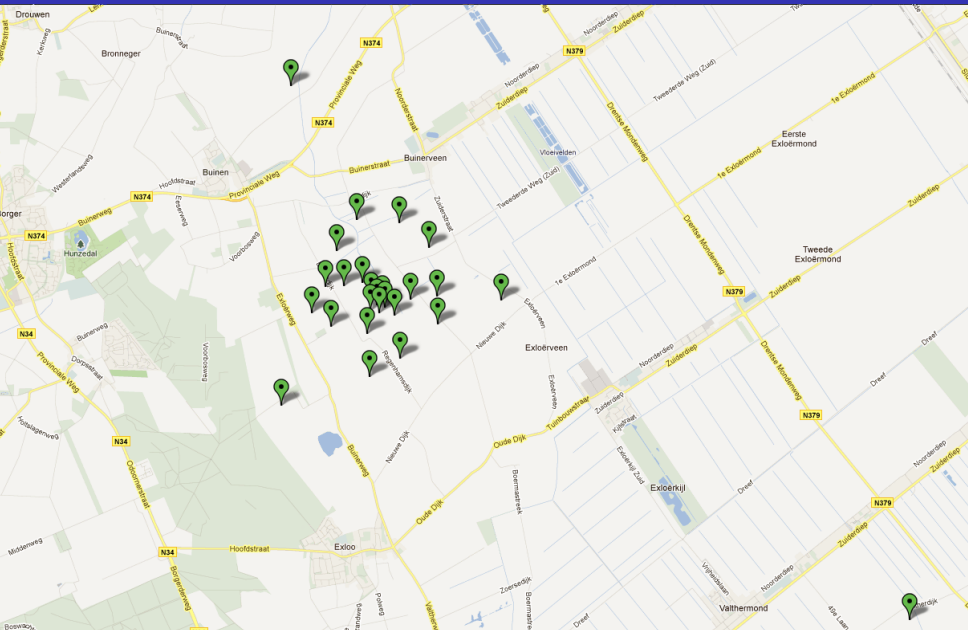

Low Band Antenna (LBA)

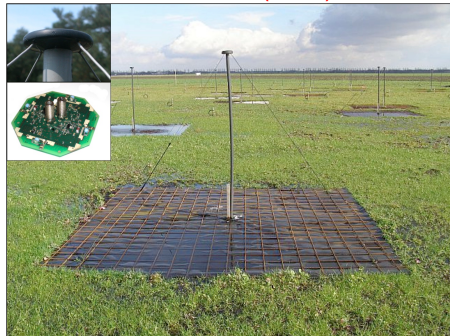

- 10–90 MHz
- All digital beam forming

High Band Antenna (HBA)



- 110–240 MHz
- 4x4 antennas per analogously beam formed tile
- Tiles beam formed digitally

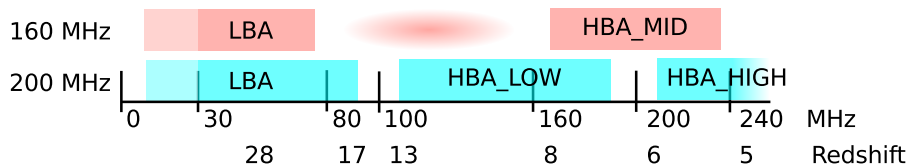

CORE

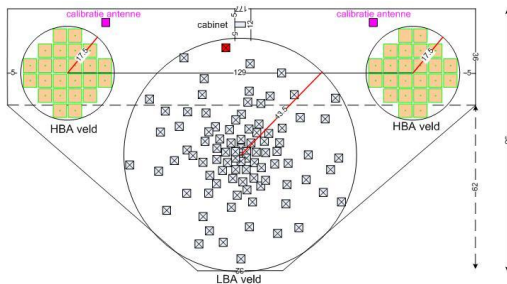

REMOTE

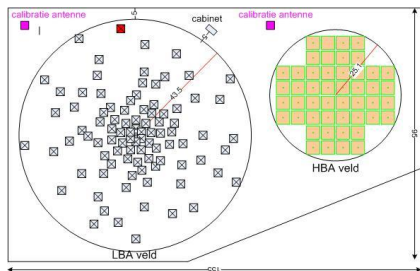

Arie Huijgen, 23 mei 2008 vs 1.0

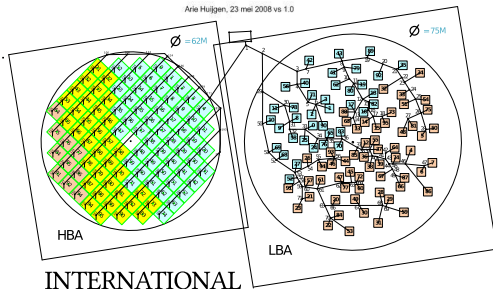

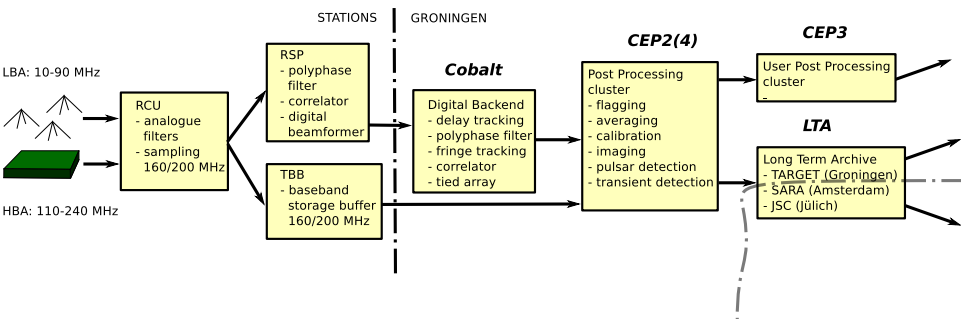
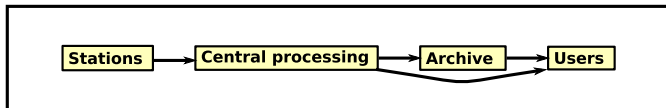

- 1 Architecture
- 2 Stations**
- 3 SHORT BREAK
- 4 Central processing
- 5 Beams, beams, beams...
- 6 More beams...
- 7 If all goes well

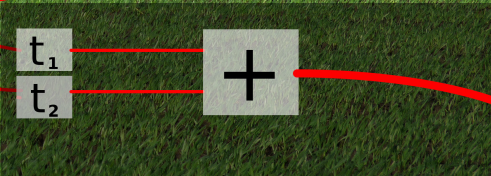
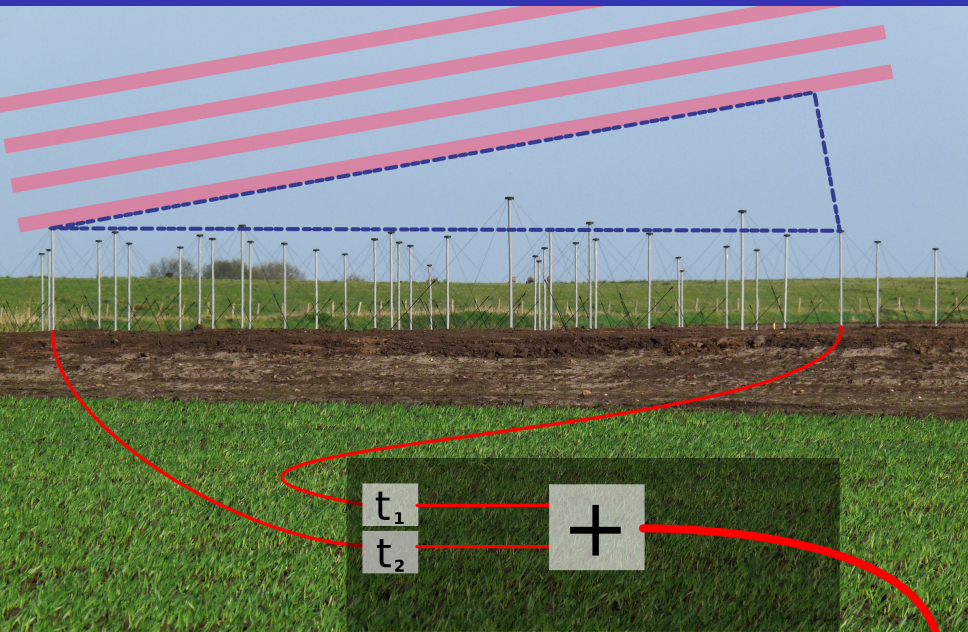

CORE

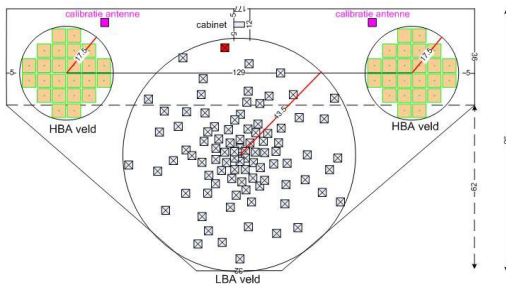

REMOTE

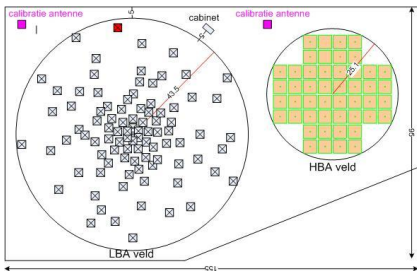

Arie Huijgen, 23 mei 2008 vs 1.0

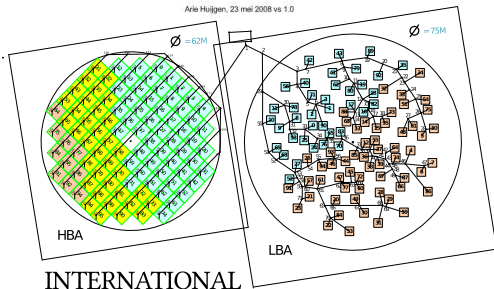

INTERNATIONAL

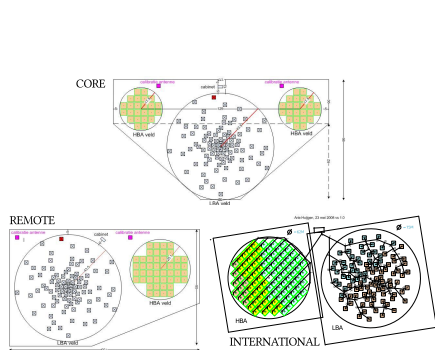

Possible cable lengths

Velocity factor ~ 0.82

Length (m)	Appr. delay (ns)
50	199
80	327
85	343
115	466
130	531

Compensated in Receiver Units
after digitization.

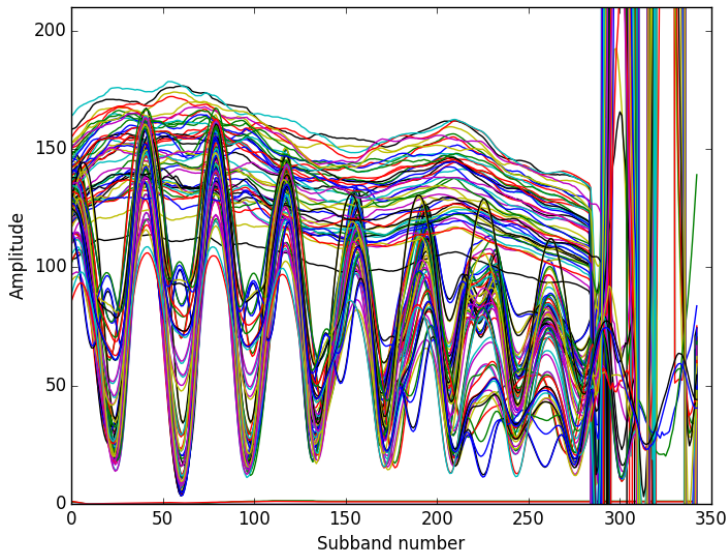

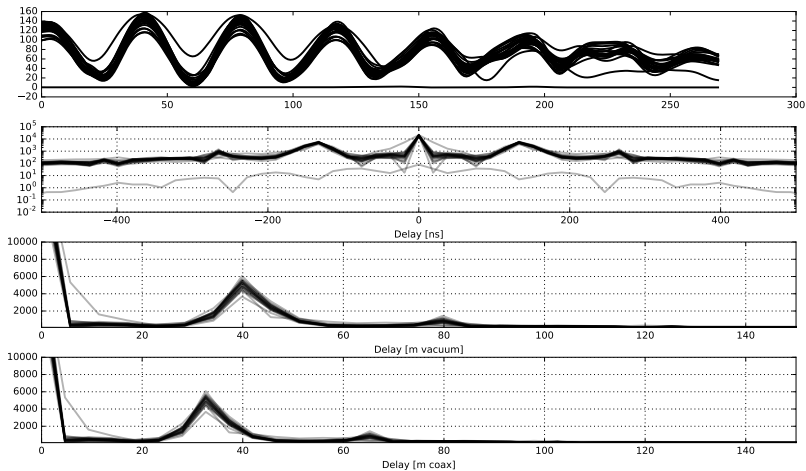

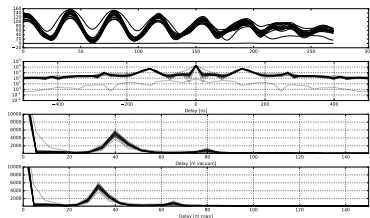

Length (m)	Appr. delay (ns)
50	199
80	327
85	343
115	466
130	531

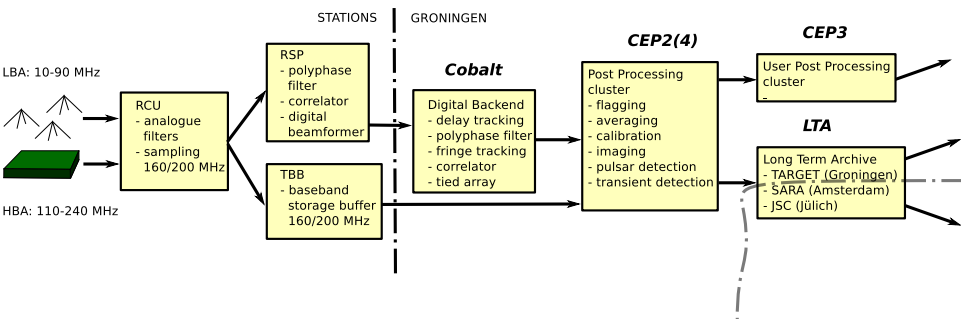
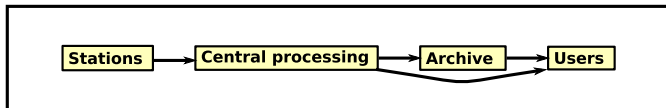

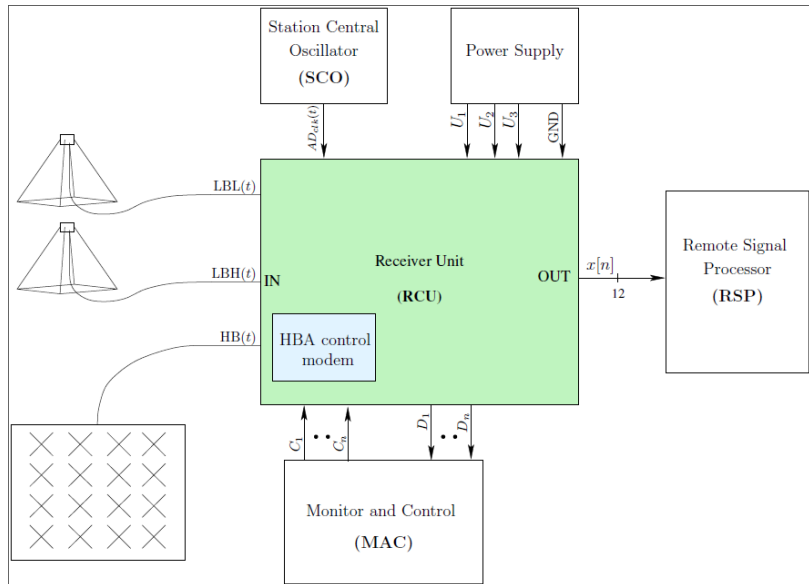

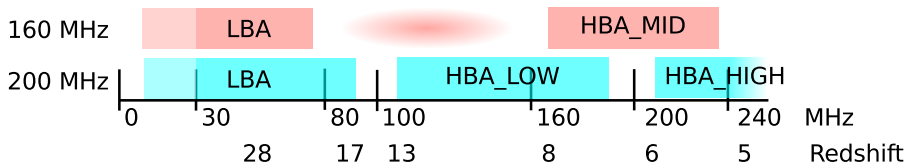
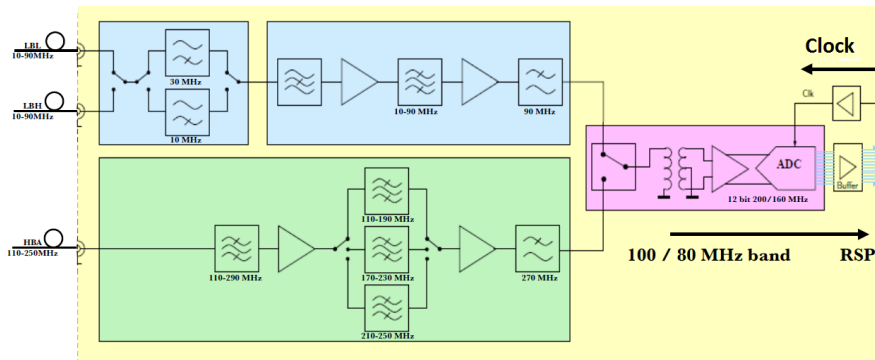

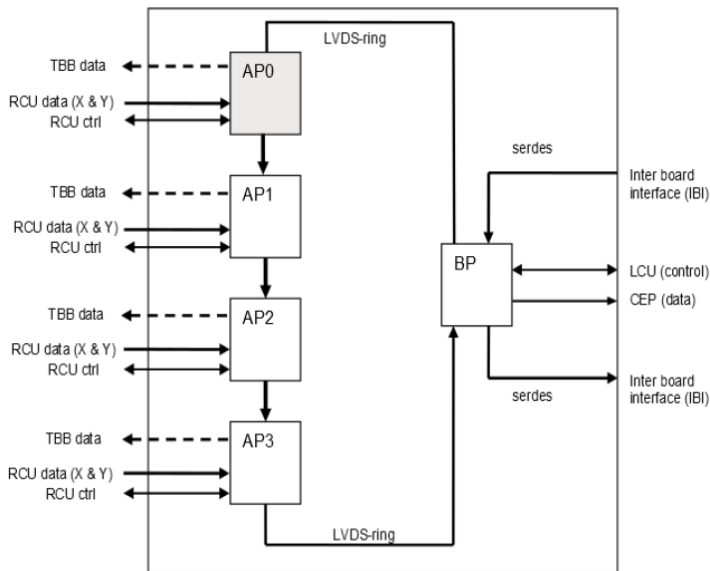

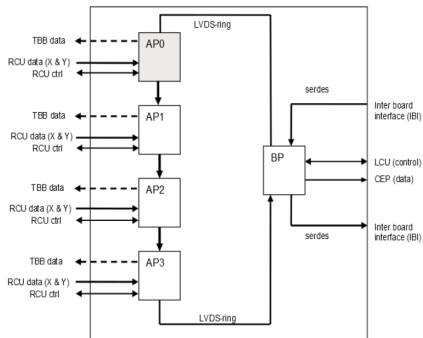

- Make 512 sub bands (polyphase filter)
- Beam forming
- Cross correlation
- Data transport to Central Processing

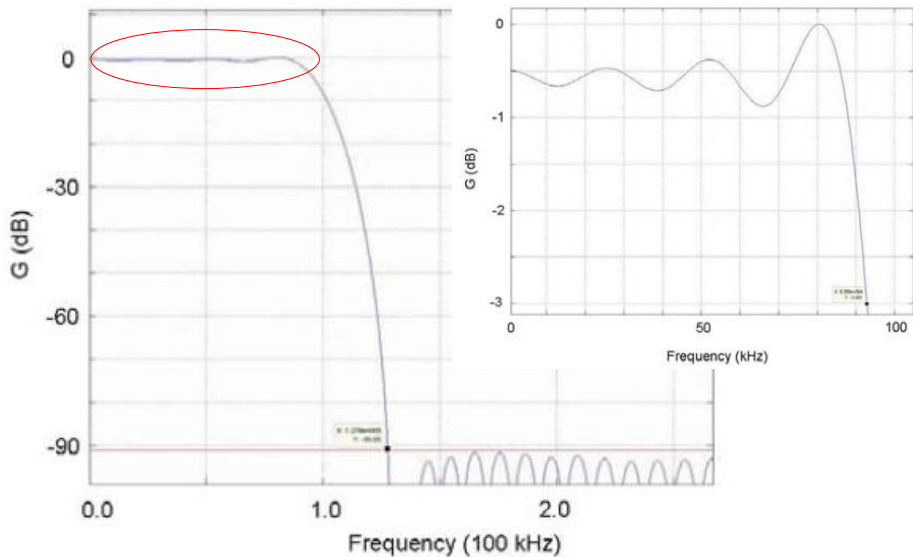

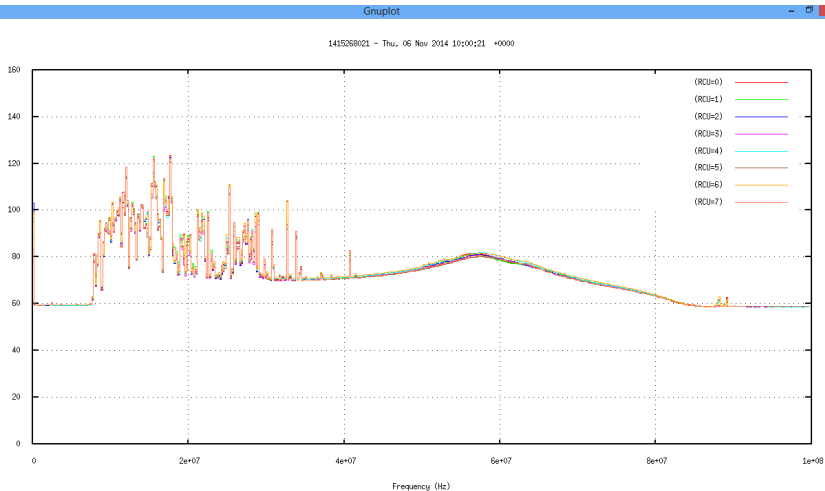

5.46947e+07, -26.0900

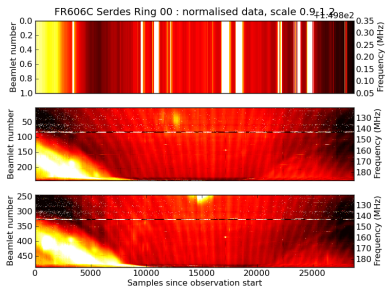
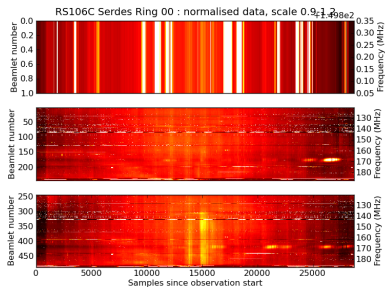
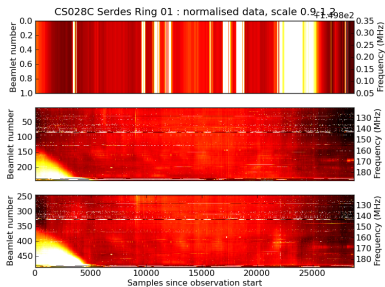
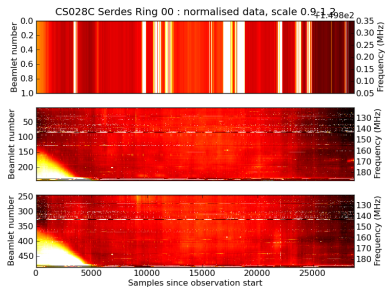



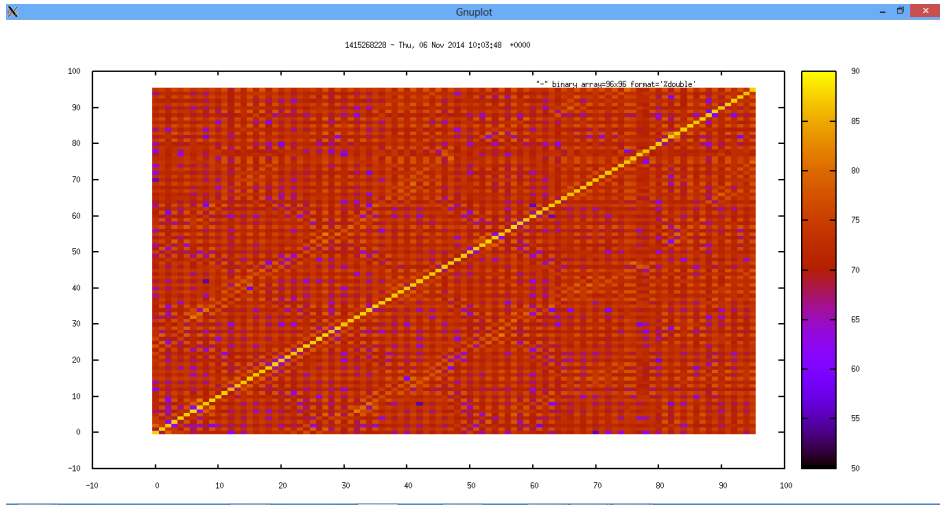

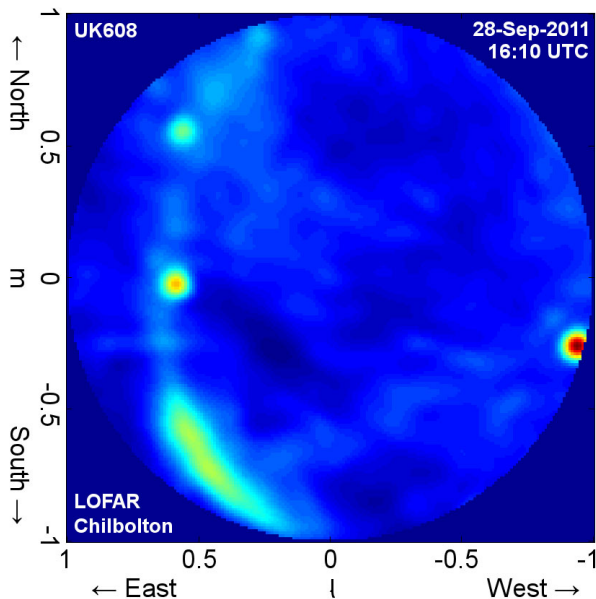

- 1 Architecture
- 2 Stations
- 3 SHORT BREAK**
- 4 Central processing
- 5 Beams, beams, beams...
- 6 More beams...
- 7 If all goes well

- 1 Architecture
- 2 Stations
- 3 SHORT BREAK
- 4 Central processing**
- 5 Beams, beams, beams...
- 6 More beams...
- 7 If all goes well



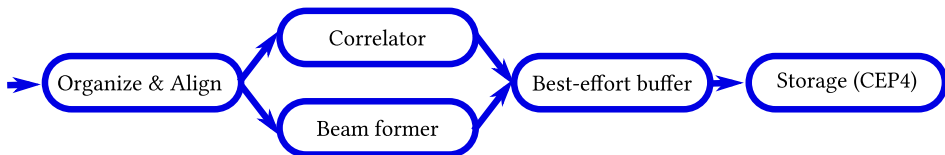

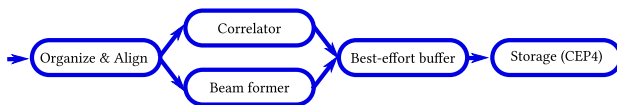

- Sort incoming data by sample time
- Flag missing data
- Transpose data from “per station: all sub bands” to “per sub band: all stations”
- Coarse delay compensation: error $2.56 \mu\text{s}$
- Ship data to GPUs

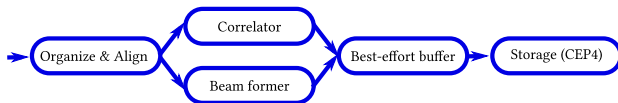

Per station

- Polyphase filter
- Compensate remaining phase slope due to coarse delay step
- station sub band bandpass correction

Per baseline per channel

- Compute

$$\begin{pmatrix} x_i x_j^* & x_i y_j^* \\ y_i x_j^* & y_i y_j^* \end{pmatrix} \quad (1)$$

- Average to 0.25 – a few s

Beamformer station bandpass correction (CS)

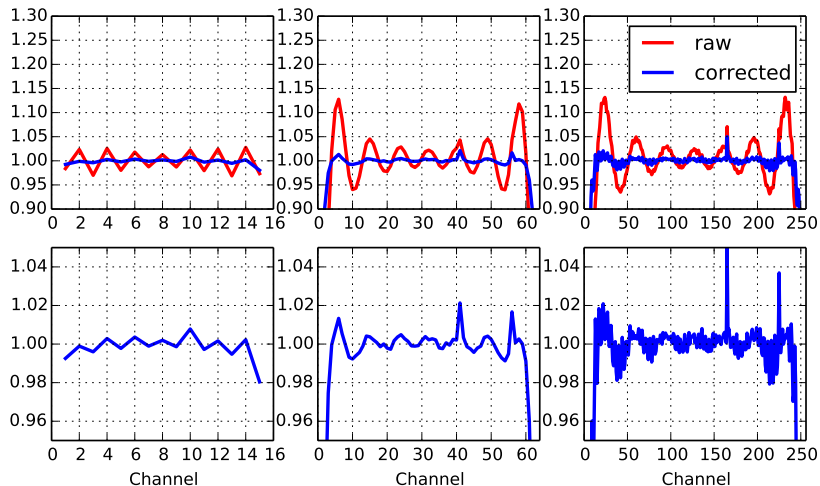

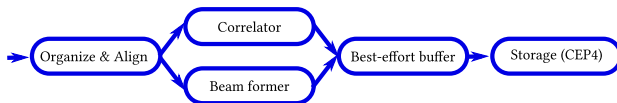

Per station

- 256pt FFT
- phase slope correction
- sub band bandpass correction
- 256pt inverse FFT

Combine all fields

- Complex Voltage: $\sum_i \mathbf{e}_i$ OR
- Coherent Stokes: $\text{Stokes}(\sum_i \mathbf{e}_i)$ OR
- Incoherent Stokes: $\sum_i \text{Stokes}(\mathbf{e}_i)$
- Average to $5.12 \mu\text{s} - \sim 0.01 \text{ s}$ (Stokes modes)
- Can be done on dozens of “tied array” beams simultaneously
- Output data rates up to 100 Gbit/s!

CEP4

- Data *REDUCTION* (tens of TB to a few TB)
- Batch processing only (Slurm)
- No user access
- Send data off to Long Term Archive (LTA)

CEP3

- user processing for limited time (\sim 4 weeks)
- all LOFAR software pre-installed
- 24 Dell PowerEdge R720 servers
- 128GB memory
- 20 Cores (2 ten-core Intel Xeon e5 2660v2 processors)
- Dell PERC H710P RAID controller 8 x 4TB disks in RAID6 setup, 22TB net disk space, XFS filesystem

- 1 Architecture
- 2 Stations
- 3 SHORT BREAK
- 4 Central processing
- 5 Beams, beams, beams...**
- 6 More beams...
- 7 If all goes well

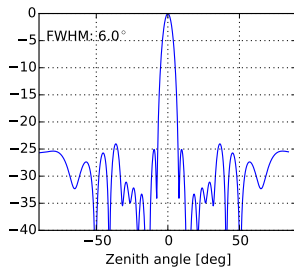
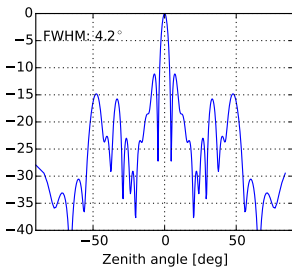
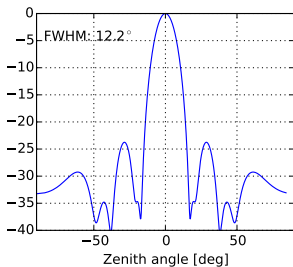
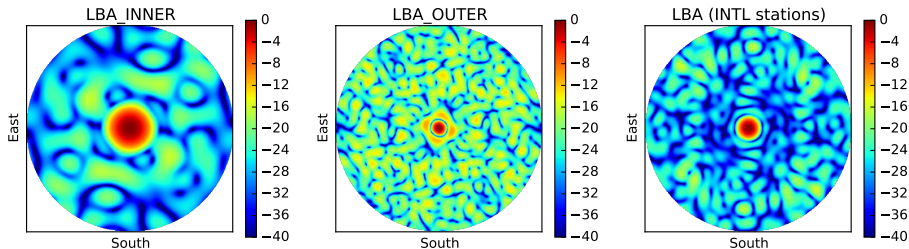



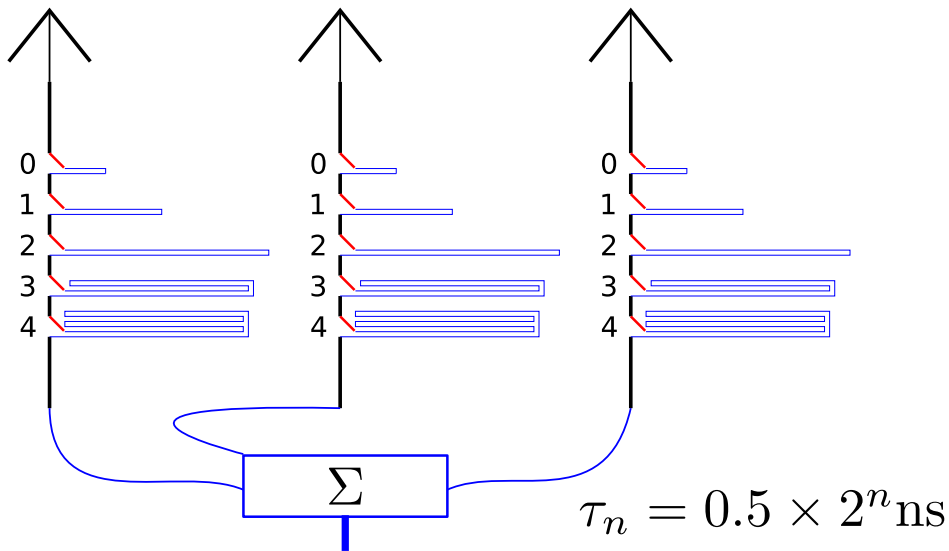

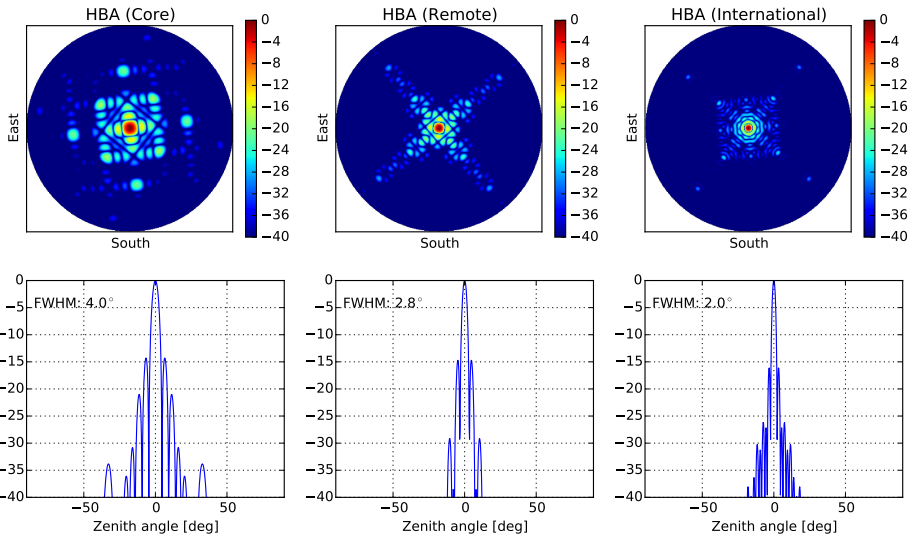

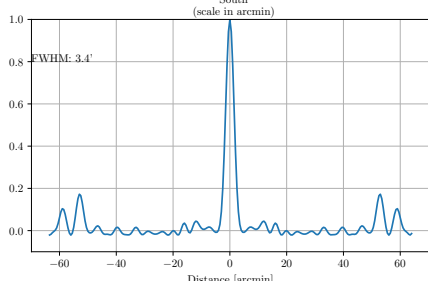
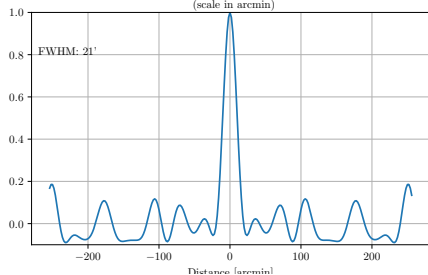
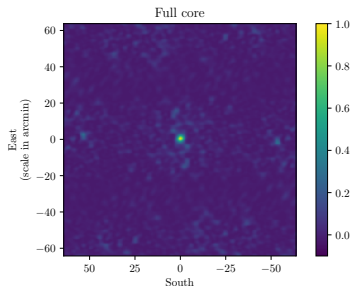
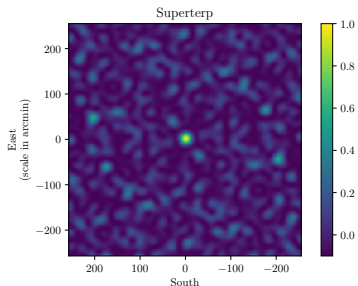

- 1 Architecture
- 2 Stations
- 3 SHORT BREAK
- 4 Central processing
- 5 Beams, beams, beams...
- 6 More beams...**
- 7 If all goes well

SE607 HBA dipole

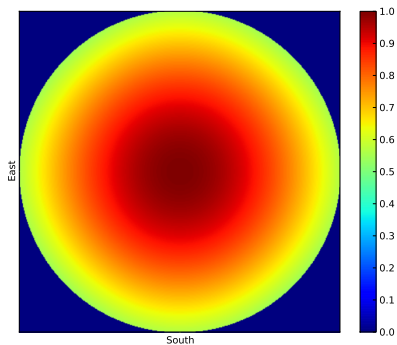
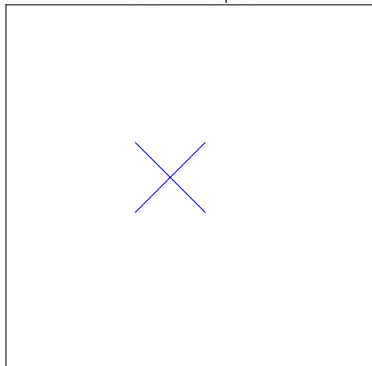

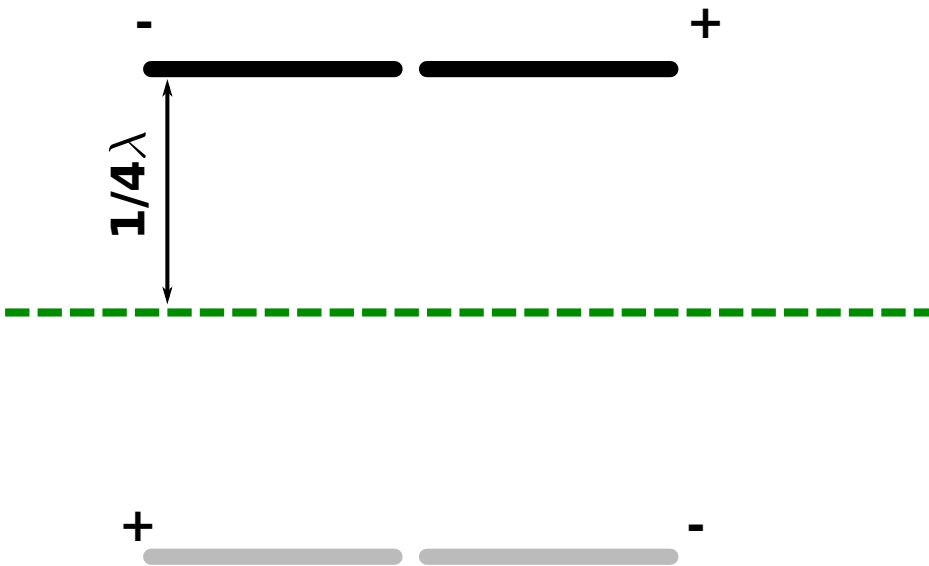

103 MHz

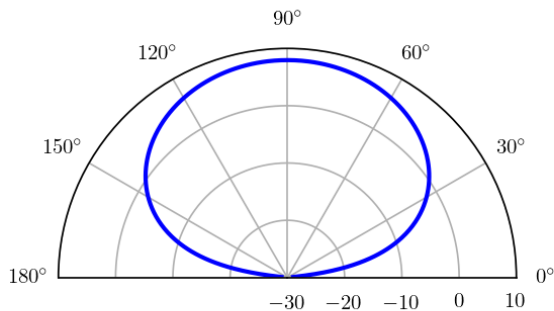

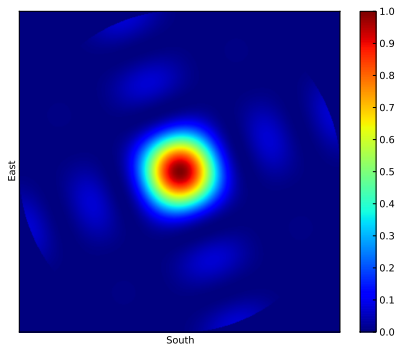
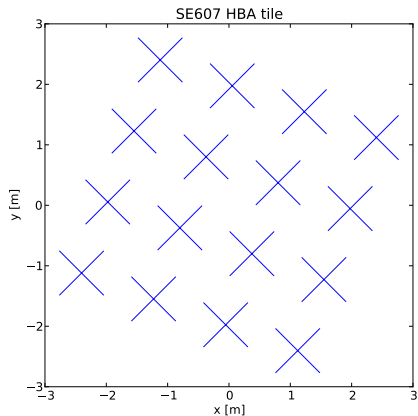

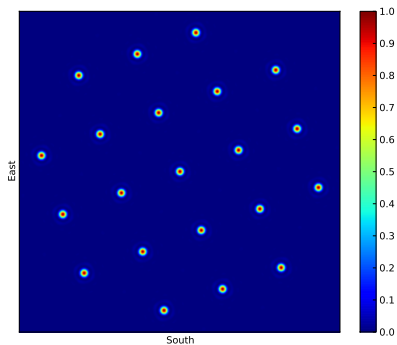
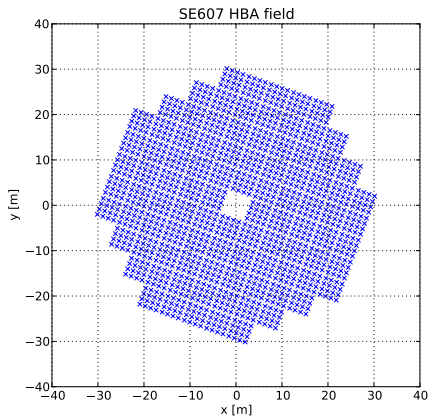

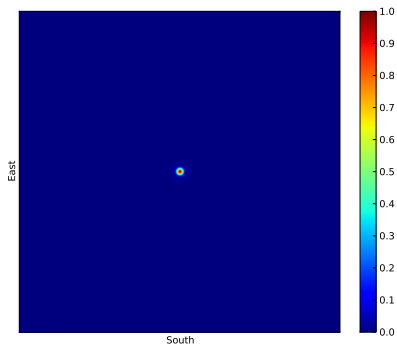
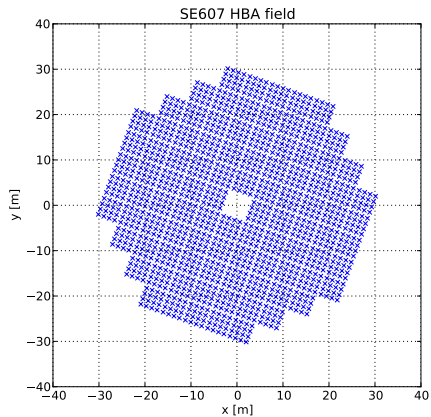

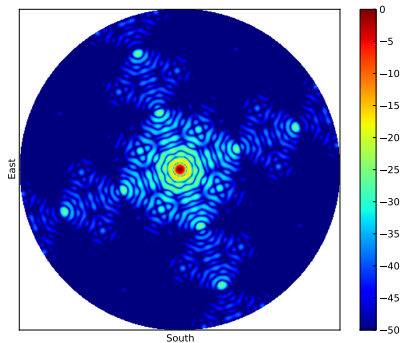
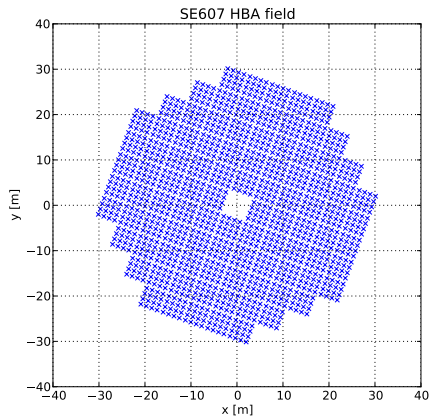

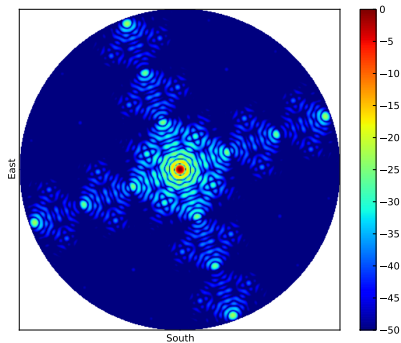
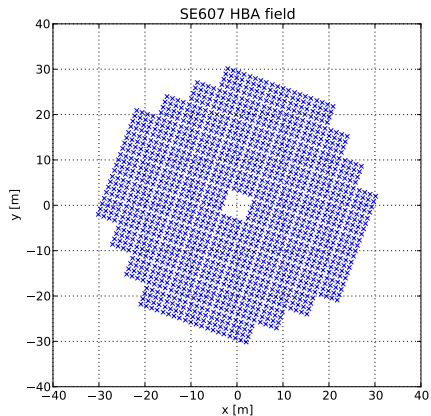

SE607 HBA field

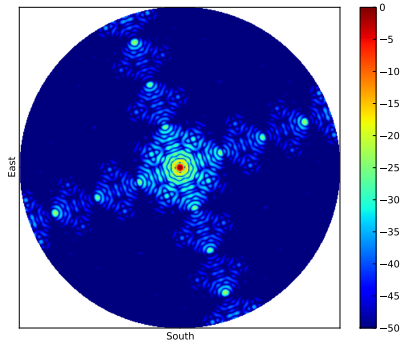
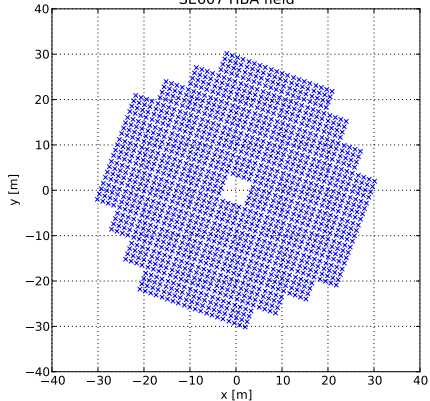

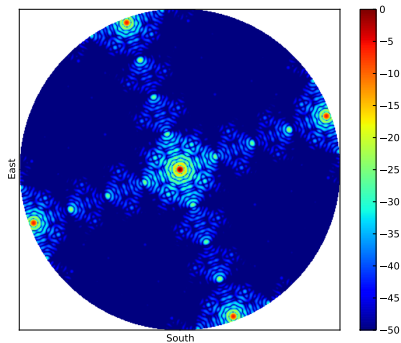
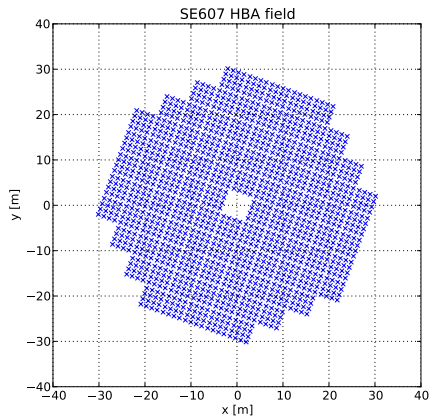

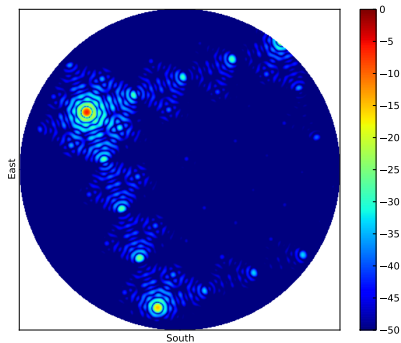
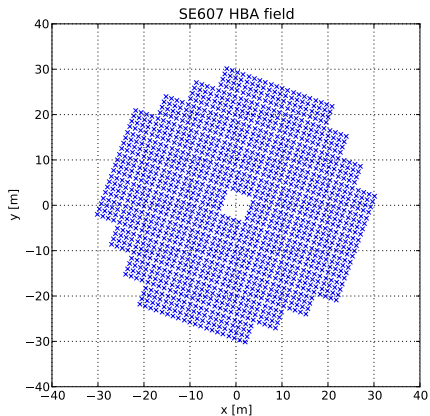

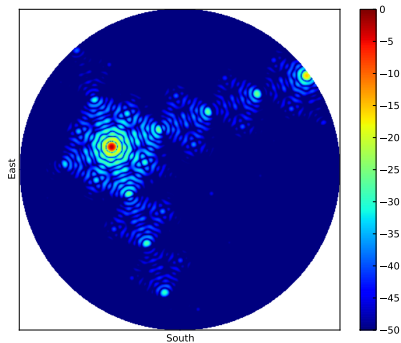
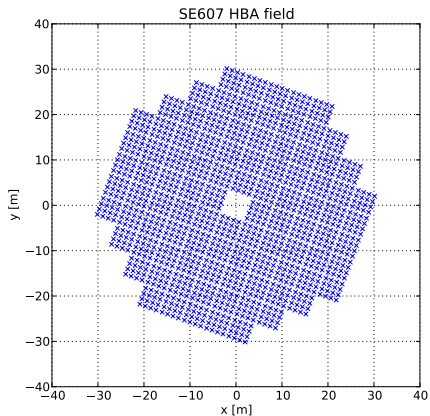

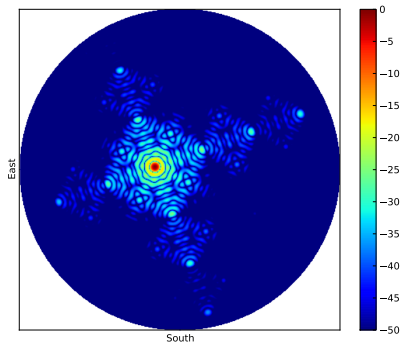
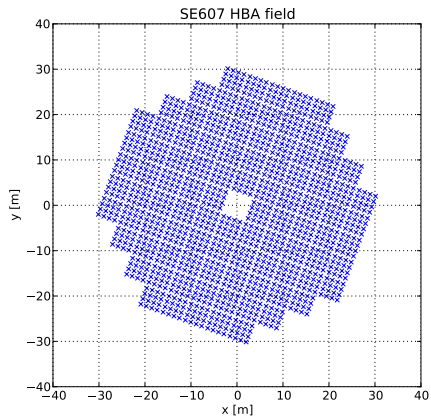

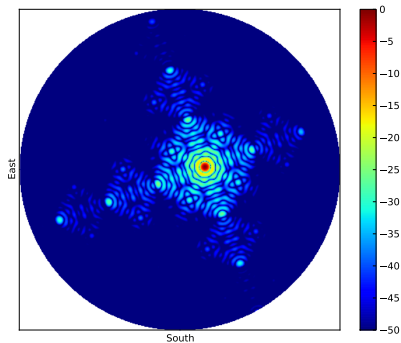
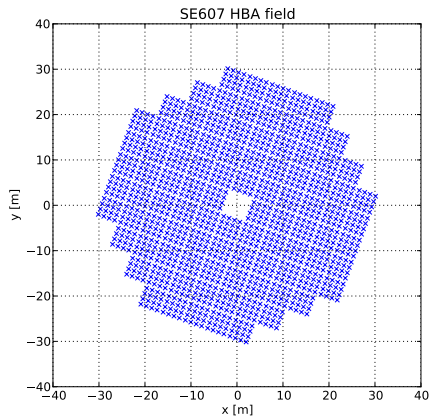

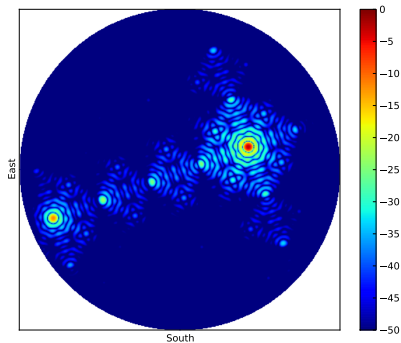
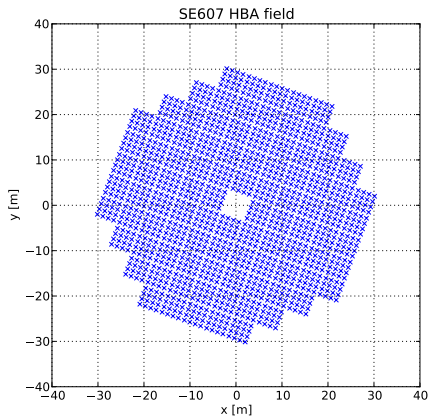

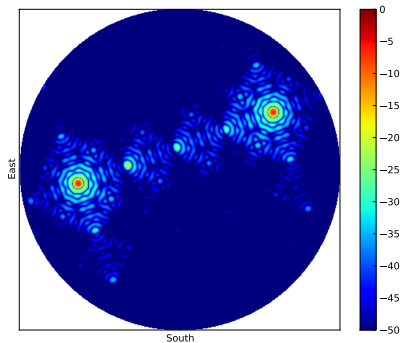
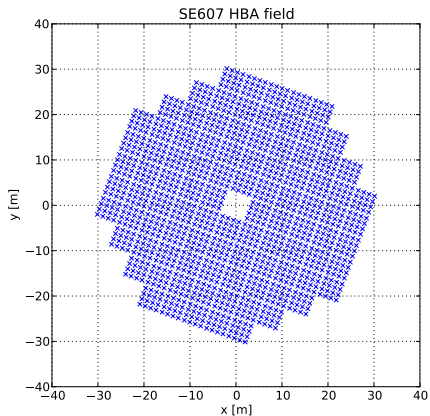

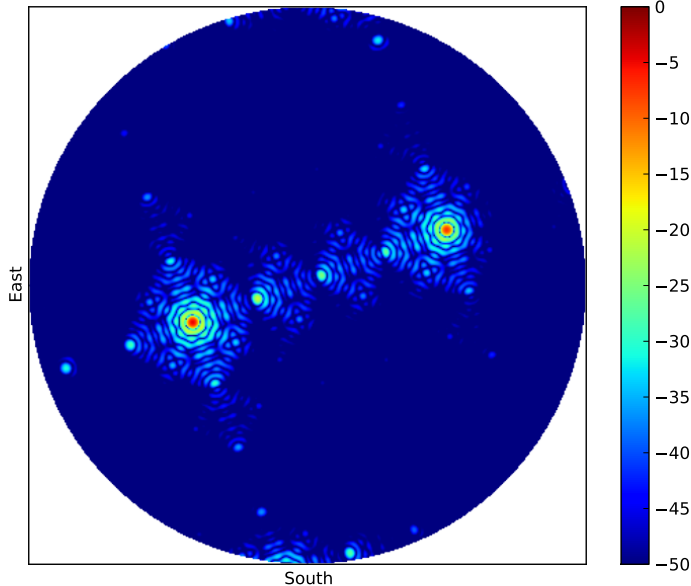

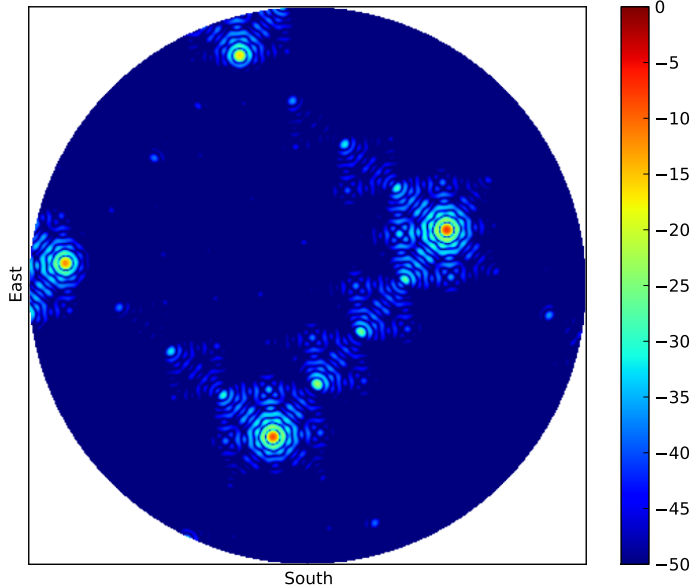

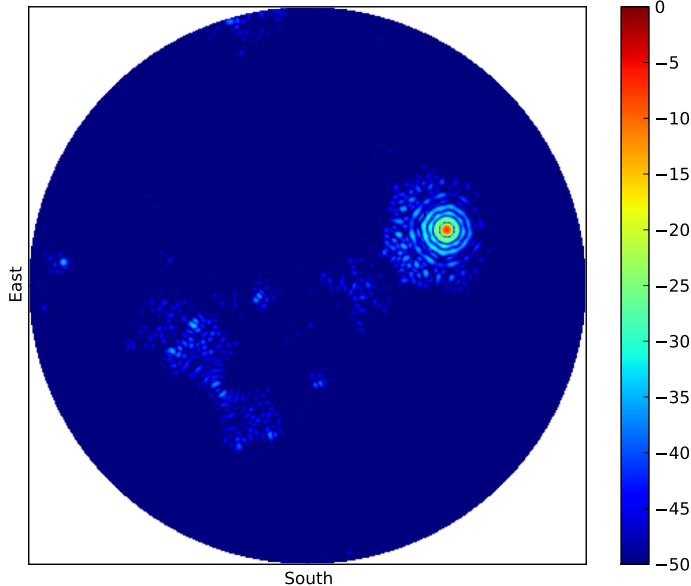

- 1 Architecture
- 2 Stations
- 3 SHORT BREAK
- 4 Central processing
- 5 Beams, beams, beams...
- 6 More beams...
- 7 If all goes well**

