

Author: M.J. Norden	Date of issue: 2007-Maa-23 Kind of issue: Limited	Scope: RCU, STS Doc.nr.: LOFAR-ASTRON-SRS-014	
	Status: Draft Revision nr.: 1.2	File: <a href="http://www.lofar.org">http://www.lofar.org</a>	

## RCU II Signal Analysis and Specification

M.J. Norden  
G.W. Kant

<b>Verified:</b>			
Name	Signature	Date	Rev.nr.
	.....	2007-Maa-23	1.2

<b>Accepted:</b>		
Work Package Manager	System Engineering Manager	Program Manager
M.J. Norden	A. Gunst	J. Reitsma
.....	.....	.....
<i>date:</i>	<i>date:</i>	<i>date:</i>

©ASTRON 2007  
All rights are reserved. Reproduction in whole or in part is prohibited without the written consent of the copyright owner.

Author: M.J. Norden	Date of issue: 2007-Maa-23 Kind of issue: Limited	Scope: RCU, STS Doc.nr.: LOFAR-ASTRON-SRS-014	
	Status: Draft Revision nr.: 1.2	File: <a href="http://www.lofar.org">http://www.lofar.org</a>	

## Distribution list:

---

Group:	For Information:
ASTRON A.W. Gunst G.W. Kant J. Morawietz G.W. Schoonderbeek	ASTRON J. Bregman W. van Cappellen A. Huijgen E. Kooistra Y. Koopman M. Ruiter E. van der Wal S.J. Wijnholds E.E.M. Woestenburg

## Document revision:

---

Revision	Date	Section	Page(s)	Modification
0.1	2005-Jul-21	-	-	Creation
1.0	2005-Sep-7	-	-	Released
1.1	2005-Nov-9	-	-	Linearity increased
1.2	2007-Maa-23	-	-	48V power supply and HBA modem

Author: M.J. Norden	Date of issue: 2007-Maa-23 Kind of issue: Limited	Scope: RCU, STS Doc.nr.: LOFAR-ASTRON-SRS-014	
	Status: Draft Revision nr.: 1.2	File: <a href="http://www.lofar.org">http://www.lofar.org</a>	

### Abstract

In this document the LOFAR receiver system requirements are specified. The corresponding analysis, which forms the basis for these specifications is included.

Author: M.J. Norden	Date of issue: 2007-Maa-23 Kind of issue: Limited	Scope: RCU, STS Doc.nr.: LOFAR-ASTRON-SRS-014	
	Status: Draft Revision nr.: 1.2	File: <a href="http://www.lofar.org">http://www.lofar.org</a>	

## Contents

<b>1 Introduction</b>	<b>6</b>
1.1 Scope . . . . .	6
1.2 Related Documents . . . . .	6
1.3 General description . . . . .	6
<b>2 Receiver system analysis</b>	<b>8</b>
<b>3 Functionality of the RCU</b>	<b>13</b>
3.1 LB: mode 1 . . . . .	14
3.2 HB: mode 2 . . . . .	15
3.3 HB: mode 3 . . . . .	16
3.4 HB: mode 4 . . . . .	17
3.5 A/D converter and Amplifier Model . . . . .	18
3.5.1 Quantization noise . . . . .	18
3.5.2 Timing jitter noise . . . . .	19
3.5.3 Amplifier noise . . . . .	20
3.6 Filter transfer requirements . . . . .	21
3.6.1 Low Band: mode 1a . . . . .	21
3.6.2 Low Band: mode 1b . . . . .	22
3.6.3 High Band: mode 2 . . . . .	22
3.6.4 High Band: mode 3 . . . . .	23
3.6.5 High Band: mode 4 . . . . .	23
3.7 RCU specifications . . . . .	24

Author: M.J. Norden	Date of issue: 2007-Maa-23 Kind of issue: Limited	Scope: RCU, STS Doc.nr.: LOFAR-ASTRON-SRS-014	
	Status: Draft Revision nr.: 1.2	File: <a href="http://www.lofar.org">http://www.lofar.org</a>	

3.8	Control RCU-II . . . . .	26
3.8.1	HBA control modem . . . . .	27
3.9	Power supply requirements . . . . .	29
<b>A</b>	<b>Control RCU-I</b>	<b>31</b>
<b>B</b>	<b>Cable loss: Coax-9</b>	<b>31</b>
<b>C</b>	<b>Block diagram RCU-II</b>	<b>32</b>

Author: M.J. Norden	Date of issue: 2007-Maa-23 Kind of issue: Limited	Scope: RCU, STS Doc.nr.: LOFAR-ASTRON-SRS-014	
	Status: Draft Revision nr.: 1.2	File: <a href="http://www.lofar.org">http://www.lofar.org</a>	

# 1 Introduction

## 1.1 Scope

This document defines the signal specifications for the ReCeiver Unit (RCU) based on the requirements of the LOw Frequency ARray (LOFAR). Also included in this document is the corresponding analysis forming the base for these specifications. The specifications are applicable to the prototype Final Test Station (FTS).

Detailed specifications are given in this document for the following items:

- Frequency Range
- Band selection
- Selectivity
- Noise model for the A/D converter
- Sampling frequency
- Small signal gain
- Noise figure/temperature
- Linearity
- System bandwidth
- Control
- Power supply

## 1.2 Related Documents

The LOFAR large signal specifications are deduced in [1]. The measurement results of RCU II are described in [2].

## 1.3 General description

The frequency range of LOFAR is covered in two frequency bands respectively denoted as Low Band (LB) and High Band (HB). The low frequency band is defined from 10 to 90 MHz and the high band from

Author: M.J. Norden	Date of issue: 2007-Maa-23 Kind of issue: Limited	Scope: RCU, STS Doc.nr.: LOFAR-ASTRON-SRS-014	
	Status: Draft Revision nr.: 1.2	File: <a href="http://www.lofar.org">http://www.lofar.org</a>	

110 to 240 MHz. For the low band two different antenna variants can be used. One is used to extend the sensitivity below 40 MHz, the other covers the 30 to 80 MHz frequency range. The high band antenna is formed by 16 dual polarized dipoles. The high band antenna comprises an analog beamformer, hence the receiver provides inputs for all three antenna.

The RCU interfaces between the antenna elements and the Remote Station Processor (RSP). The function of the RCU is to select one band out of the three input frequency bands and to convert the selected signal towards the digital domain. In Fig. 1, the signals are running from left to right. The signals  $LBL(t)$ ,  $LBH(t)$  are the LB signal inputs and  $HB(t)$  the HB signal input. The selected signal  $s(t)$  is digitized and represented at the output as  $x[n] = x(n \cdot T_s)$ , where  $T_s$  is a period of the sampling clock  $AD_{clk}(t)$ <sup>1</sup> in seconds (s). The sampling clock is provided by the Station Central Oscillator. In order to provide the required functionality and to enable control, additional signals from Monitoring And Control (MAC) and the power supplies are necessary. The digital output signal is passed to the RSP unit for further processing and filtering. In Fig. 1 only one receiver is connected to the RSP unit.

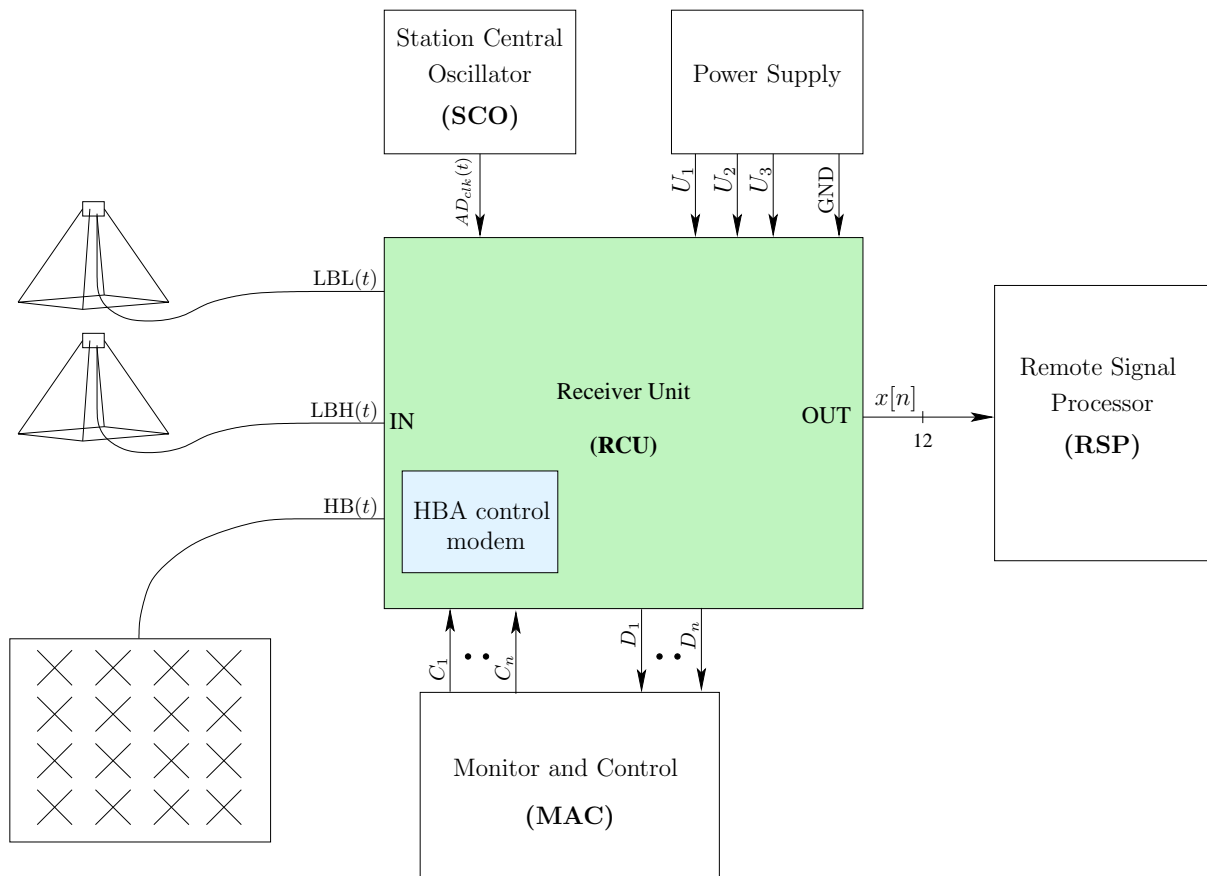



Figure 1: *The interfaces of the RCU.*

<sup>1</sup>In Fig. 1, the interior signals in the RCU, like  $s(t)$ , are not shown. Only the exterior signals, i.e. the signals at the interfaces, are shown.

Author: M.J. Norden	Date of issue: 2007-Maa-23 Kind of issue: Limited	Scope: RCU, STS Doc.nr.: LOFAR-ASTRON-SRS-014	
	Status: Draft Revision nr.: 1.2	File: <a href="http://www.lofar.org">http://www.lofar.org</a>	

## 2 Receiver system analysis

In this section the gain and noise specifications for the receiver system will be derived. The receiver system consists of different active antennas, coaxial cables and a receiver unit. First, the gain and noise distribution of the complete receiver system is analysed. With this analysis the gain and noise specifications for the RCU can be defined. The gain and noise distribution is well balanced between RCU and antennas. A model of one input band of the receiver system is given in Fig. 2.

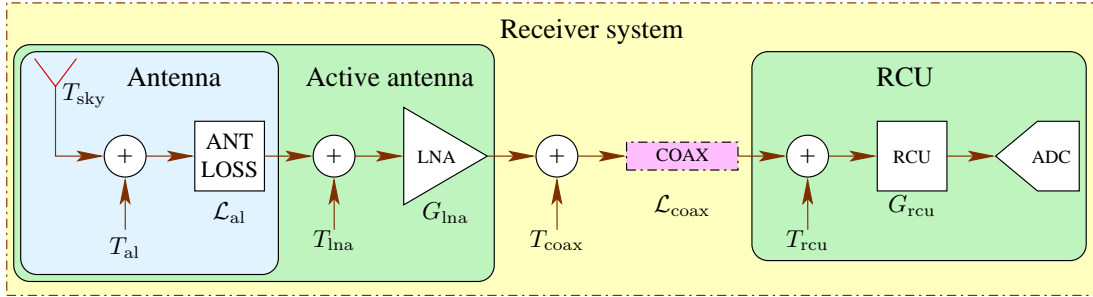

Figure 2: A one band receiver system model.

In this model, the antenna losses are represented explicitly separated from the antenna. The antenna is assumed lossless and therefore it provides only a representation of the sky noise. When the lossless antenna is terminated with a load  $Z_l = Z_a^*$ , where  $Z_a^*$  is the complex conjugate of the (lossless) antenna impedance, the available noise power is delivered to the load. For the available noise power it follows from thermodynamics

$$N_a = \int_B k \cdot T_a(f) df, \quad (1)$$

where  $k = 1.38 \cdot 10^{-23}$  J/K is Boltzmann's constant,  $B$  is the frequency range which is under consideration and  $T_a(f)$  is the antenna noise temperature in Kelvin (K) at frequency  $f$ . For the antenna noise temperature,  $T_a(f)$  it follows

$$T_a(f) = \frac{1}{4 \cdot \pi} \iint_{\Omega} D(\theta, \varphi) \cdot T_{\text{sky}}(\theta, \varphi) d\Omega, \quad (2)$$

where  $D(\theta, \varphi)$  is the directivity of the antenna element and  $T_{\text{sky}}(\theta, \varphi)$  is the sky noise temperature in direction  $(\theta, \varphi)$  and at frequency  $f$ . It is assumed that  $T_{\text{sky}}(\theta, \varphi)$  is stationary and constant for directions towards the sky and furthermore the influence of the earth is ignored. With this the antenna noise temperature is approximated as

$$T_a(f) = T_{\text{sky}}(f). \quad (3)$$

The following empiric equation is used to model the sky noise temperature:

$$T_{\text{sky}}(f) = T_{1\text{K}} \cdot \left\{ \left( \frac{c}{f \cdot l_o} \right)^{2.55} + \left( \frac{f}{f_o} \right)^{1.8} \right\} + T_{\text{bg}}, \quad (4)$$



Author: M.J. Norden	Date of issue: 2007-Maa-23 Kind of issue: Limited	Scope: RCU, STS Doc.nr.: LOFAR-ASTRON-SRS-014	
	Status: Draft Revision nr.: 1.2	File: <a href="http://www.lofar.org">http://www.lofar.org</a>	

In this equation  $c = 3 \cdot 10^8$  m/s is the speed of light in vacuum,  $T_{1K}$  is a constant equal to 1 Kelvin,  $l_o$  is a constant equal to 0.2008 meter,  $f_o$  is a constant equal to 10 GHz and  $T_{bg} = 2.7$  K is the background noise temperature. A plot of the antenna noise temperature is shown in Fig. 3.

After having defined what is meant with the antenna noise temperature, next the receiver noise temperature is defined. Consider the case where  $T_{sky} = 0$ , i.e. the antenna receives no signal. All the noise at the output of the receiver is generated by the receiver system itself and this noise is denoted as excess noise  $N_x$ . In general, when  $T_{sky} \neq 0$ , the noise at the output of the receiver  $N_{out}$  is given by

$$N_{out} = \int_B g_{sys}(f) \cdot k \cdot T_a(f) df + N_x, \quad (5)$$

where  $g_{sys}(f)$  is the total available gain from the lossless antenna to the output. Finally, the excess noise is modeled as a noise source at the input of the receiver represented as an equivalent receiver noise temperature  $T_{rec}(f)$

$$N_x = \int_B g_{sys}(f) \cdot k \cdot T_{rec}(f) df \quad (6)$$

From (6),  $T_{rec}(f)$  can be deduced, since it is valid for arbitrarily small  $B$ . Having defined the equivalent receiver noise temperature  $T_{rec}(f)$ , (5) can be rewritten as

$$N_{out} = \int_B g_{sys}(f) \cdot k \cdot \{T_a(f) + T_{rec}(f)\} df \quad (7)$$

and with this form the phrase “being sky noise limited” is defined. The somewhat vague requirement “sky noise limited” is reinterpreted here as

*In the absence of RFI, the output receiver noise density shall be dominated by the sky noise density provided by the antenna, for all frequencies in the LOFAR frequency range.*

This is written as the following inequality

$$T_{rec}(f) < T_{sky}(f), \quad \text{for } f \in (10, 240) \setminus (90, 110) \text{ MHz} \quad (8)$$

The system noise temperature  $T_{sys}(f)$  is defined as the sum of the antenna noise temperature  $T_a(f)$  and the receiver noise temperature  $T_{rec}(f)$

$$T_{sys}(f) = T_a(f) + T_{rec}(f) \quad (9)$$

The receiver noise temperature  $T_{rec}(f)$  is the total noise temperature contribution at the input of the receiver system (12). The antenna noise temperature  $T_{ant}$  consist of  $T_{al}$  which represents the noise caused by resistive losses in the antenna element, and  $T_{lna}$  which is noise of the Low Noise Amplifier (LNA) used to amplify the antenna signal.  $l_{al}$  represents the signal attenuation caused by the losses in the antenna element.

$$T_{ant} = T_{al} + T_{lna} \cdot l_{al} \quad (10)$$

Author: M.J. Norden	Date of issue: 2007-Maa-23 Kind of issue: Limited	Scope: RCU, STS Doc.nr.: LOFAR-ASTRON-SRS-014	
	Status: Draft Revision nr.: 1.2	File: <a href="http://www.lofar.org">http://www.lofar.org</a>	

Gains denoted with capital letters are given in deciBel (dB) whereas the lower case versions represent the gain as linear numbers, e.g.

$$\mathcal{L}_{al} = 10 \cdot \log(l_{al}) \quad (11)$$

The coax cable, which connects the antenna with the RCU, also adds noise to the receiver system and is called  $T_{coax}$ . The loss introduced by the coax cable is represented by  $l_{coax}$ . The RCU noise temperature  $T_{rcu}$  is the equivalent noise temperature caused by the RCU internal amplifiers, filters, switches and analog-to-digital converter. The effective receiver noise temperature at the input of the receiver system is (see also Fig. 2)

$$T_{rec} = T_{ant} + \frac{T_{coax} \cdot l_{al}}{g_{lna}} + \frac{T_{rcu} \cdot l_{al} \cdot l_{coax}}{g_{lna}} \quad (12)$$

Now we have modeled the individual noise temperature contributions and gain distributions we can determine the necessary overall receiver system gain. The required system gain depends on the following items:

- The system noise power spectral density  $S_{nn}(f)$  in the frequency band of operation.
- The signal bandwidth  $B$  in the frequency band of operation.
- The required integrated system noise power level  $N_{ad}$  at the input of the A/D converter.

The LOFAR frequency band is divided into four sub bands (see Table 1). One for the LB, called mode 1 and three for the HB which are called mode 2, 3 and 4. Mode 1 is divided in two sub modes, called mode 1a and 1b. The antenna noise temperature  $T_a(f)$  reduces at higher frequencies. As a consequence the receiver noise temperature  $T_{rec}(f)$  should also reduce for the higher frequency bands, see equation (8). This means that it will be more difficult for the receiver system to be “sky noise limited” for mode 3 and mode 4. The antenna noise temperature, according to the model given in (4), and the maximum system noise temperature  $T_{sys}(f)(max) \leq 2 \cdot T_a(f)$  are plotted in Fig. 3.

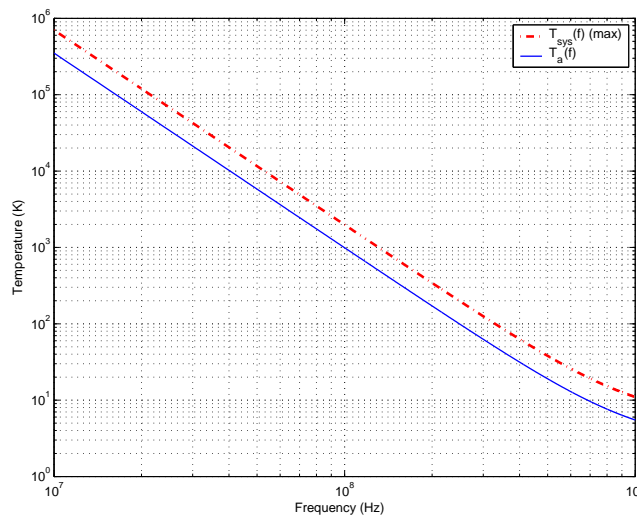



Figure 3: The antenna and system noise temperature

Author: M.J. Norden	Date of issue: 2007-Maa-23 Kind of issue: Limited	Scope: RCU, STS Doc.nr.: LOFAR-ASTRON-SRS-014	
	Status: Draft Revision nr.: 1.2	File: <a href="http://www.lofar.org">http://www.lofar.org</a>	

The system noise power spectral density is

$$S_{nn}(f) = k \cdot T_{\text{sys}}(f) \quad (13)$$

A consequence of a reduced system noise power spectral density is that the system gain needs to be proportional higher. The signal bandwidth in mode 3 and mode 4 is smaller than in the other two modes. In other words, this means more system gain is required in mode 3 and mode 4.

The maximum voltage at the input of the A/D converter is  $1.5 V_{\text{pp}}$ . With  $200 \Omega$  input impedance this corresponds with 1 mW maximum input power. For the transformation of the input signal to the digital domain we use a 12 bit A/D converter [3, 4]. For the quantization of the available noise 3 bits are reserved leaving 9 bits headroom for expected Radio Frequency Interference (RFI) signals. The available noise power at the input of the A/D converter for all receiving modes is around  $N_{\text{ad}} = 10 \text{ nW}$ . This is 50 dB below the A/D converter clip level, see Fig. 15. With a defined noise power level at the input of the A/D converter the required system gain can be calculated. The system gain is the noise power at the input of the A/D converter divided by the integrated system noise power density over the selected frequency bandwidth  $B$ . The system gain is

$$g_{\text{sys}} = \frac{N_{\text{ad}}}{\int_B S_{nn}(f) df} \quad (14)$$

According to (8) the receiver noise temperature should be smaller than the sky noise temperature. The receiver noise temperature is reduced as much as possible. For mode 1, the maximum receiver noise temperature should be limited to 20 percent of the sky noise temperature. For the other three modes the receiver noise temperature should be limited to the sky noise temperature itself. For mode 1 we split the contribution into half for the antenna and half for the coax plus RCU. For mode 2, 3 and 4 the antenna noise temperature  $T_{\text{ant}}$  (10) should be limited to at least 90 percent of the sky noise temperature in Kelvin. Leaving 10 percent or more for the rest of the system.

For the system calculation a coax cable of 100 meter length between antenna and receiver is assumed. A cable is selected with reasonable performance and price, see Appendix B. The loss of a coax cable increases with frequency and length. The higher loss in the upper LOFAR frequency bands is compensated with more gain in the High Band Antenna (HBA). Once the loss is known the noise temperature of the coax can be calculated by

$$T_{\text{coax}} = (l_{\text{coax}} - 1) \cdot T_{\text{amb}} \quad (15)$$

Author: M.J. Norden	Date of issue: 2007-Maa-23 Kind of issue: Limited	Scope: RCU, STS Doc.nr.: LOFAR-ASTRON-SRS-014	
	Status: Draft Revision nr.: 1.2	File: <a href="http://www.lofar.org">http://www.lofar.org</a>	

With  $T_{amb}$  being the ambient temperature of the coax cable. The total system gain needs a good balance between  $G_{ant}$  and  $G_{rcu}$ . The antenna gain  $G_{ant}$  is the sum of the LNA gain and the losses in the antenna element.

$$G_{ant} = G_{la} + G_{lna} \quad (16)$$

To make the noise of the coax and the RCU less dominant  $G_{ant}$  should be as high as possible. For LB mode 1, the available gain is supposed to be  $G_{ant} = 7$  dB. For the HBA the available gain is supposed to be  $G_{ant} = 30$  dB. The gain is assumed here constant, but is in practice frequency dependent. When the gain slope of the antenna in combination with the coax cable is small, then the assumption could be used to calculate the requirements for the system gain and noise temperature. The calculated values are tabulated in Table 1.

Table 1: The receiver system calculation

Band	Mode	Freq Band (MHz)	B (MHz)	$T_{sky}$ (K)	$G_{sys}$ (dB)	$T_{rec}$ (K)	$G_{ant}$ (dB)	$T_{ant}$ (K)	$G_{coax}$ (dB)	$T_{coax}$ (K)	$G_{rcu}$ (dB)	$T_{rcu}$ (K)
LB	1	10-90	80	27515	24	5503	7	2752	-5	627	22	4163
HB	2	110-190	80	395	41	395	30	356	-8	1540	19	6016
HB	3	170-230	60	177	45	177	30	159	-9	2014	24	1975
HB	4	210-270	60	122	47	122	30	110	-10	2610	27	959

To make the comparison between individual noise temperature contributions easier, the noise temperature of the coax cable and receiver have been calculated at the input of the receiver system, see Table 2.

Table 2: Noise temperature contributions at the input of the receiver system

Band	Mode	Freq Band (MHz)	B (MHz)	$G_{sys}$ (dB)	$T_{sys}$ (K)	$T_{sky}$ (K)	$T_{rec}$ (K)	$T_{ant}$ (K)	$T_{coax}$ @ input (K)	$T_{rcu}$ @ input (K)
LB	1	10-90	80	24	33018	27515	5503	2752	125	2626
HB	2	110-190	80	41	790	395	395	356	2	38
HB	3	170-230	60	45	354	177	177	159	2	16
HB	4	210-270	60	47	244	122	122	110	3	10

The requirements for the RCU are different for the four individual sub bands. To meet these requirements, the receiver subsystem building blocks like filters, switches and amplifiers need to be specified. In Section 3 the RCU is described. For every mode the building block specifications are given.

Author: M.J. Norden	Date of issue: 2007-Maa-23 Kind of issue: Limited	Scope: RCU, STS Doc.nr.: LOFAR-ASTRON-SRS-014	
	Status: Draft Revision nr.: 1.2	File: <a href="http://www.lofar.org">http://www.lofar.org</a>	

### 3 Functionality of the RCU

The RCU contains two major analog signal paths. One for the two LB antennas and one for the HB antenna. The LB signal path can process the signals from either the LBL antenna or the LBH antenna. The LB signal path has a switchable highpass input filter to reduce RFI signals if required. The HB signal path contains three switchable bandpass filters to select the required frequency band. All analog signal paths have different gain settings because the antenna signal levels and the noise requirements are different. One of the two signal paths can be switched to the buffer amplifier and A/D converter. A block diagram of the RCU is given in Fig. 4.

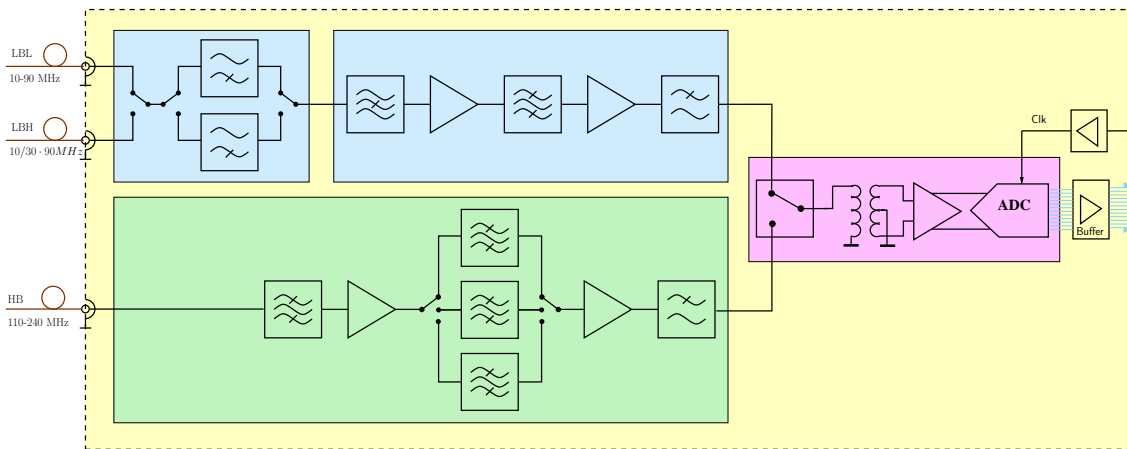



Figure 4: *Block diagram RCU.*

The LB receiver modes are described in more detail in section 3.1 and the HB receiver modes in section 3.2, 3.3 and 3.4. The common signal path, formed by the impedance transformer, buffer amplifier and A/D converter is described in section 3.5. The filter requirements are described and depicted in section 3.6. The specifications for all LB and HB receiving modes are described in section 3.7. The control of the RCU and the high band antenna is described in section 3.8. The power supply requirements for RCU and antennas are summarized in section 3.9. A more detailed block diagram of the RCU can be found in Appendix C.

Author: M.J. Norden	Date of issue: 2007-Maa-23 Kind of issue: Limited	Scope: RCU, STS Doc.nr.: LOFAR-ASTRON-SRS-014	
	Status: Draft Revision nr.: 1.2	File: <a href="http://www.lofar.org">http://www.lofar.org</a>	

### 3.1 LB: mode 1

The LB receiver has two antenna inputs. One is the Low Band Low (LBL) input and the other the Low Band High (LBH) input. The LBL antenna input is available for the very low frequency antenna (not yet developed). Depending on the strength of the RFI signals, a 10 MHz or 30 MHz High Pass Filter (HPF) can be selected. The LB antenna signal is further amplified and filtered in the analog LB receiver chain, see Fig. 5. The frequency band is from 10 to 90 MHz. The building blocks are specified with Gain (G) or Insertion Loss (IL) and Noise Figure (NF).

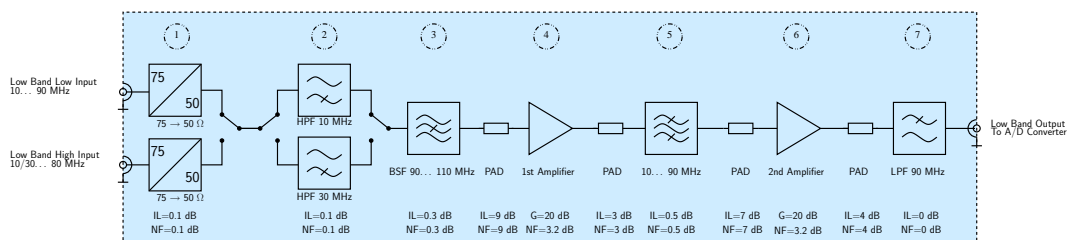



Figure 5: *Block diagram of the analog LB receiver chain: mode 1*

- (1) 75 to 50 Ohm impedance transformer. This is to match the coax characteristic impedance with the 50 Ohm receiver input impedance.
- (2) Selectable 10 MHz or 30 MHz highpass filter. When the RFI signals are too strong in the SW frequency band, the highpass filter can be set to 30 MHz. Normally the 10 MHz highpass filter is selected.
- (3) 90..110 MHz bandstop filter. This filter is to reduce the RFIs mainly caused by the FM band, so the requirements on linearity of the succeeding amplifier (4) is reduced.
- (4) First amplifier. This amplifier should have a low noise figure and high gain. The pads are used to adapt the gain and to maintain a good 50 Ohm source and load impedance for this amplifier.
- (5) 10..90 MHz bandpass filter. This is the band selecting filter. This filter should have at least 80 dB stopband attenuation 10 MHz outside the band of interest. The filter specifications are depicted in section 3.6.
- (6) Second amplifier. This amplifier may have a higher noise figure and should have sufficient gain to fill the lowest three bits of the A/D converter with sky noise.
- (7) 90 MHz lowpass filter. This anti-aliasing filter should reduce the out of band noise before the signal is sampled by the A/D converter.

Author: M.J. Norden	Date of issue: 2007-Maa-23 Kind of issue: Limited	Scope: RCU, STS Doc.nr.: LOFAR-ASTRON-SRS-014	
	Status: Draft Revision nr.: 1.2	File: <a href="http://www.lofar.org">http://www.lofar.org</a>	

## 3.2 HB: mode 2

The HB antenna signal is amplified and filtered in the analog HB receiver chain, see Fig. 6. The frequency band is from 110 to 190 MHz.

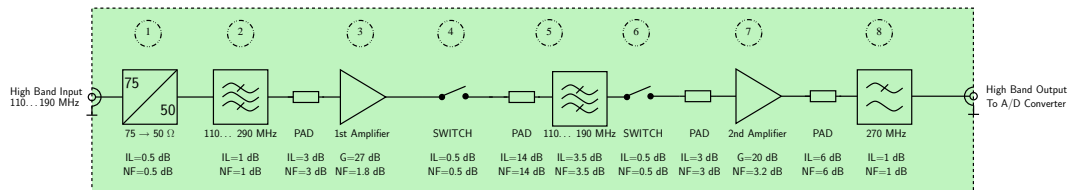



Figure 6: *Block diagram of the analog HB receiver chain: mode 2*

- (1) 75 to 50 Ohm impedance transformer. This is to match the coax characteristic impedance with the 50 Ohm receiver input impedance.
- (2) 110..290 MHz bandpass filter. This filter is to reduce the out of band noise and RFIs, so the requirements on linearity of the succeeding amplifier (3) is reduced.
- (3) First amplifier. This amplifier should have a low noise figure and high gain. The pads are used to adapt the gain and to maintain a good 50 Ohm source and load impedance for this amplifier.
- (4) Band switch 1. To select the correct bandpass filter.
- (5) 110..190 MHz bandpass filter. This is the band selecting filter. This filter should have at least 80 dB stopband attenuation 10 MHz outside the band of interest. The pad is used to adapt the gain difference for the individual subbands. The filter specifications are depicted in section 3.6.
- (6) Band switch 2. To select the correct bandpass filter.
- (7) Second amplifier. This amplifier may have a higher noise figure and should have sufficient gain to fill the lowest three bits of the A/D converter with sky noise.
- (8) 270 MHz lowpass filter. This anti-aliasing filter should reduce the out of band noise before the signal is sampled by the A/D converter.

Author: M.J. Norden	Date of issue: 2007-Maa-23 Kind of issue: Limited	Scope: RCU, STS Doc.nr.: LOFAR-ASTRON-SRS-014	
	Status: Draft Revision nr.: 1.2	File: <a href="http://www.lofar.org">http://www.lofar.org</a>	

### 3.3 HB: mode 3

The HB antenna signal is amplified and filtered in the analog HB receiver chain, see Fig. 7. The frequency band is from 170 to 230 MHz.

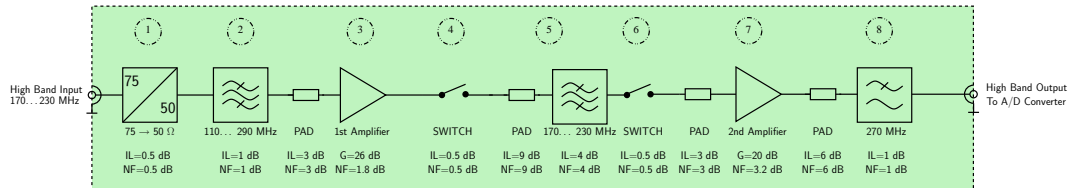



Figure 7: Block diagram of the analog HB receiver chain: mode 3

- (1) 75 to 50 Ohm impedance transformer. This is to match the coax characteristic impedance with the 50 Ohm receiver input impedance.
- (2) 110..290 MHz bandpass filter. This filter is to reduce the out of band noise and RFIs, so the requirements on linearity of the succeeding amplifier (3) is reduced.
- (3) First amplifier. This amplifier should have a low noise figure and high gain. The pads are used to adapt the gain and to maintain a good 50 Ohm source and load impedance for this amplifier.
- (4) Band switch 1. To select the correct bandpass filter.
- (5) 170..230 MHz bandpass filter. This is the band selecting filter. This filter should have at least 80 dB stopband attenuation 10 MHz outside the band of interest. The pad is used to adapt the gain difference for the individual subbands. The filter specifications are depicted in section 3.6.
- (6) Band switch 2. To select the correct bandpass filter.
- (7) Second amplifier. This amplifier may have a higher noise figure and should have sufficient gain to fill the lowest three bits of the A/D converter with sky noise.
- (8) 270 MHz lowpass filter. This anti-aliasing filter should reduce the out of band noise before the signal is sampled by the A/D converter.



Author: M.J. Norden	Date of issue: 2007-Maa-23 Kind of issue: Limited	Scope: RCU, STS Doc.nr.: LOFAR-ASTRON-SRS-014	
	Status: Draft Revision nr.: 1.2	File: <a href="http://www.lofar.org">http://www.lofar.org</a>	

### 3.4 HB: mode 4

The HB antenna signal is amplified and filtered in the analog HB receiver chain, see Fig. 8. The frequency band is from 210 to 270 MHz.

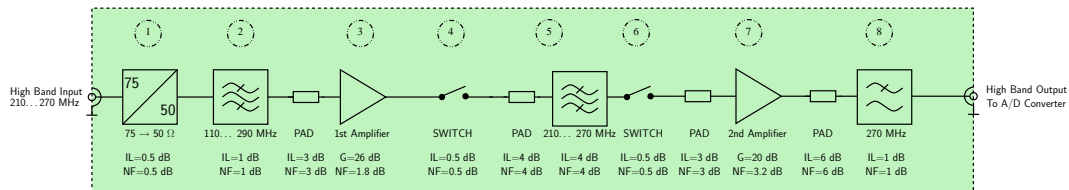



Figure 8: *Block diagram of the analog HB receiver chain: mode 4*

- (1) 75 to 50 Ohm impedance transformer. This is to match the coax characteristic impedance with the 50 Ohm receiver input impedance.
- (2) 110..290 MHz bandpass filter. This filter is to reduce the out of band noise and RFIs, so the requirements on linearity of the succeeding amplifier (3) is reduced.
- (3) First amplifier. This amplifier should have a low noise figure and high gain. The pads are used to adapt the gain and to maintain a good 50 Ohm source and load impedance for this amplifier.
- (4) Band switch 1. To select the correct bandpass filter.
- (5) 210..270 MHz bandpass filter. This is the band selecting filter. This filter should have at least 80 dB stopband attenuation 10 MHz outside the band of interest. The pad is used to adapt the gain difference for the individual subbands. The filter specifications are depicted in section 3.6.
- (6) Band switch 2. To select the correct bandpass filter.
- (7) Second amplifier. This amplifier may have a higher noise figure and should have sufficient gain to fill the lowest three bits of the A/D converter with sky noise.
- (8) 270 MHz lowpass filter. This anti-aliasing filter should reduce the out of band noise before the signal is sampled by the A/D converter.

Author: M.J. Norden	Date of issue: 2007-Maa-23 Kind of issue: Limited	Scope: RCU, STS Doc.nr.: LOFAR-ASTRON-SRS-014	
	Status: Draft Revision nr.: 1.2	File: <a href="http://www.lofar.org">http://www.lofar.org</a>	

### 3.5 A/D converter and Amplifier Model

The common signal path for the LB and the HB receiver is formed by the buffer amplifier with A/D converter section. The input of the A/D converter can be switched between the LB analog receiver chain and the HB analog receiver chain, see Fig. 9. In this section we will calculate the individual noise contributions and gain to see if they match with the receiver requirements (see Table 1).

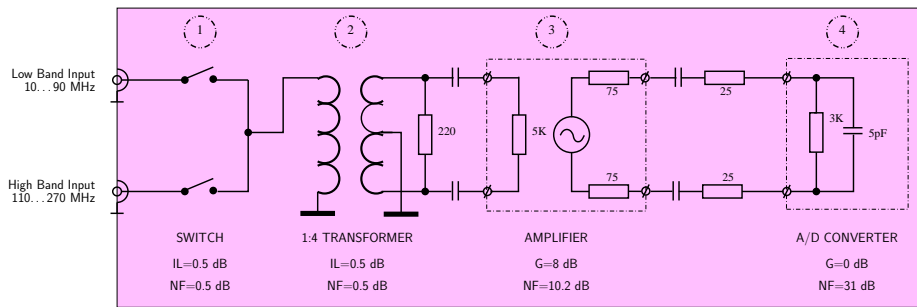

Figure 9: Block diagram of the buffer amplifier and A/D converter

- (1) Single Pole Double Throw (SPDT) switch. To switch the input of the A/D converter between the analog LB or HB receiver chain.
- (2) 1:4 Impedance transformer. To match the 50 Ohm output impedance with the 200 Ohm buffer amplifier input impedance. The transformer forms also a balun. This reduces the influence of power supply noise, because the input signal is balanced in the transformer.
- (3) Buffer amplifier. This amplifier should buffer and amplify the analog signals from the LB and HB receiver chain.
- (4) 12 bit A/D converter. This converter transforms the analog input signal into the digital domain

The noise generated in the A/D converter is split in a quantization noise part and a noise part generated by the non idealities of the A/D converter. Time jitter is assumed to be the main non-ideal noise contributor of the A/D converter [4].

#### 3.5.1 Quantization noise

The noise temperature  $T_q$  at the input of the A/D converter caused by quantization noise is [3]

$$T_q = \frac{E[V_q^2]}{4 \cdot k \cdot (Z_{adc} \parallel Z_{amp}) \cdot B} \quad (\text{K}) \quad (17)$$

Author: M.J. Norden	Date of issue: 2007-Maa-23 Kind of issue: Limited	Scope: RCU, STS Doc.nr.: LOFAR-ASTRON-SRS-014	
	Status: Draft Revision nr.: 1.2	File: <a href="http://www.lofar.org">http://www.lofar.org</a>	

with

$$E[V_q^2] = \frac{q^2}{12} \quad (\text{V}^2) \quad (V^2)$$

The noise figure  $NF_q$  due to quantization noise is

$$NF_q = 10 \cdot \log \left( 1 + \frac{T_q}{T_{amb}} \right) \quad (\text{dB}) \quad (18)$$

For a 12 bit A/D converter with 1.5 V full scale voltage  $V_{FS}$ , the quantization step  $q$  is 366  $\mu\text{V}$ . The output impedance of the buffer amplifier  $Z_{amp} = 200 \Omega$  and the input impedance of the A/D converter is  $Z_{adc} = 3 \text{ k}\Omega$ . The quantization noise temperature depends on the bandwidth  $B$ . For a single sided spectrum the bandwidth is half the sample frequency of the A/D converter  $B = F_s/2$ . For a 200 MHz sample frequency the quantization noise temperature  $T_q$  is 10798 Kelvin. The quantization noise power density  $S_{qq}$  is

$$S_{qq}(f) = 10 \cdot \log(k \cdot T_q) + 30 \quad (\text{dBm/Hz}) \quad (19)$$

If the quantization noise would be the only noise contribution source, the minimum noise power density at the input of the A/D converter is -158.2 dBm/Hz. Other noise sources like timing jitter and thermal noise of the buffer amplifier also contributes to the A/D converter noise floor.

### 3.5.2 Timing jitter noise

In this system calculation all additional noise originating from non-ideal sources is modeled to be jitter generated in the A/D converter and A/D converter clock. The time jitter noise is [4]

$$E[V_j^2] = (V_{FS} \cdot \pi \cdot f_o \cdot \delta t_j)^2 \quad (\text{V}^2) \quad (20)$$

with  $f_o$  the highest input frequency to be expected (worst case) and  $\delta t_j$  the RMS timing jitter. The noise temperature  $T_j$  at the input of the A/D converter caused by the clock jitter noise is

$$T_j = \frac{E[V_j^2]}{4 \cdot k \cdot (Z_{adc} \parallel Z_{amp}) \cdot B} \quad (\text{K}) \quad (21)$$

Suppose a full-scale input signal with  $f_o = 45 \text{ MHz}$  and  $\delta t_j = 0.5 \text{ ps}$ , the noise temperature  $T_j$  is 10862 Kelvin. The noise figure  $NF_j$  due to time jitter is

$$NF_j = 10 \cdot \log \left( 1 + \frac{T_j}{T_{amb}} \right) \quad (\text{dB}) \quad (22)$$

When we calculate the noise power density contribution due to time jitter  $S_{jj}$

$$S_{jj}(f) = 10 \cdot \log(k \cdot T_j) + 30 \quad (\text{dBm/Hz}) \quad (23)$$

The contribution at 45 MHz is also -158.2 dBm/Hz. This brings the total noise power density due to the A/D converter to -155.2 dBm/Hz. Apart from the A/D converter, the buffer amplifier also contributes to the noise floor.

Author: M.J. Norden	Date of issue: 2007-Maa-23 Kind of issue: Limited	Scope: RCU, STS Doc.nr.: LOFAR-ASTRON-SRS-014	
	Status: Draft Revision nr.: 1.2	File: <a href="http://www.lofar.org">http://www.lofar.org</a>	

### 3.5.3 Amplifier noise

The noise of the buffer amplifier is specified as noise voltage source. The maximum noise voltage of the AD8351 is  $V_n = 2.9 \text{ nV}/\sqrt{\text{Hz}}$ . The noise power density of the amplifier is

$$N_{amp} = E[V_n^2] \quad (\text{V}^2/\text{Hz}) \quad (24)$$

The thermal noise density of the source impedance is

$$N_{source} = 4 \cdot k \cdot T_{amb} \cdot R_{source} \quad (\text{V}^2/\text{Hz}) \quad (25)$$

The source impedance of the amplifier is  $R_{source} = 200 \Omega$  ( $4 * 50 \Omega$ ). In parallel with this impedance a resistor is placed called  $R_{parallel} = 220 \Omega$ , see Figure 9. The noise figure of the amplifier is

$$NF_{amp} = 10 \cdot \log \left[ 1 + \frac{4 \cdot k \cdot T_{amb} \cdot (R_{source})^2}{R_{parallel}} + \frac{N_{amp} \cdot \left( \frac{R_{source} + R_{parallel}}{R_{parallel}} \right)^2}{N_{source}} \right] \quad (26)$$

With  $T_{amb} = 290$  Kelvin being the input source temperature according IEEE standard definitions, the noise figure of the amplifier  $NF_{amp}$  is 10.2 dB. The equivalent noise temperature is  $T_{amp} = 2747$  Kelvin.

The noise temperature contribution of the amplifier at the input of the A/D converter is amplified with the available gain of the buffer amplifier  $G_{amp}$ . The available gain of the differential buffer amplifier is 8 dB.

Table 3: The A/D converter system noise calculation

Freq Band (MHz)	$f_o$ (MHz)	$G_{amp} \cdot T_{amp}$ (K)	$T_q$ (K)	$T_j$ (K)	$[G_{amp} \cdot T_{amp}] + T_q + T_j$ (K)	$NF$ (dB)	$SS_{tot}$ (dBm/Hz)
10-90	90	17330	10798	43448	71576	23.9	-150.1
110-190	190	17330	10798	193637	221766	28.8	-145.1
170-230	230	17330	13497	354689	385517	31.2	-142.7
210-270	270	17330	10798	391029	419158	31.6	-142.4

From Table 3 it is clear that the noise contribution due to time jitter is the dominant noise source in the A/D amplifier model. The A/D converter with amplifier and transformer have been measured and the results are close to the values predicted by the model. The measured noise power spectral density was -143 dBm/Hz with a 239 MHz full-scale continuous wave signal. At 25 MHz the noise power spectral density was measured -144 dBm/Hz. This is 10 dB more then the -154 dBm/Hz we would have with an ideal clock signal. This is probably because the effective number of bits is lower then the specified number of twelve bits. The effective number of bits ENOB is 10.2 bits [2]

Author: M.J. Norden	Date of issue: 2007-Maa-23 Kind of issue: Limited	Scope: RCU, STS Doc.nr.: LOFAR-ASTRON-SRS-014	
	Status: Draft Revision nr.: 1.2	File: <a href="http://www.lofar.org">http://www.lofar.org</a>	

### 3.6 Filter transfer requirements

The requirements for the analog filters are partly derived from the digital filter requirements. The stopband attenuation should be at least 80 dB (91 dB nice to have). The required stopband attenuation is based on assumption 2 [5]. Assumption 2 is reformulated here as:

*The total aliased power in a station sub band (156/195 kHz) shall be at least 10dB below the original sky noise power in this sub band before beam forming*

The maximum passband ripple for the analog filters is 2 dB (0.5 dB for the digital filters). The Insertion Loss (IL) for the filters is not critical. The IL is compensated with additional gain in front of the filters. The requirements are valid for the all LB and HB bandpass filters.

#### 3.6.1 Low Band: mode 1a

The low band filter passband is between 10 MHz and 90 MHz. In this mode the bandpass filter is preceded with a 10 MHz highpass filter. Between 10 MHz and 30 MHz more ripple and attenuation is allowed. The total filter transfer is given in Fig. 10. The low band mode 1a and 1b are sampled in the first nyquist zone with 200 MHz sampling frequency (see Table 4).

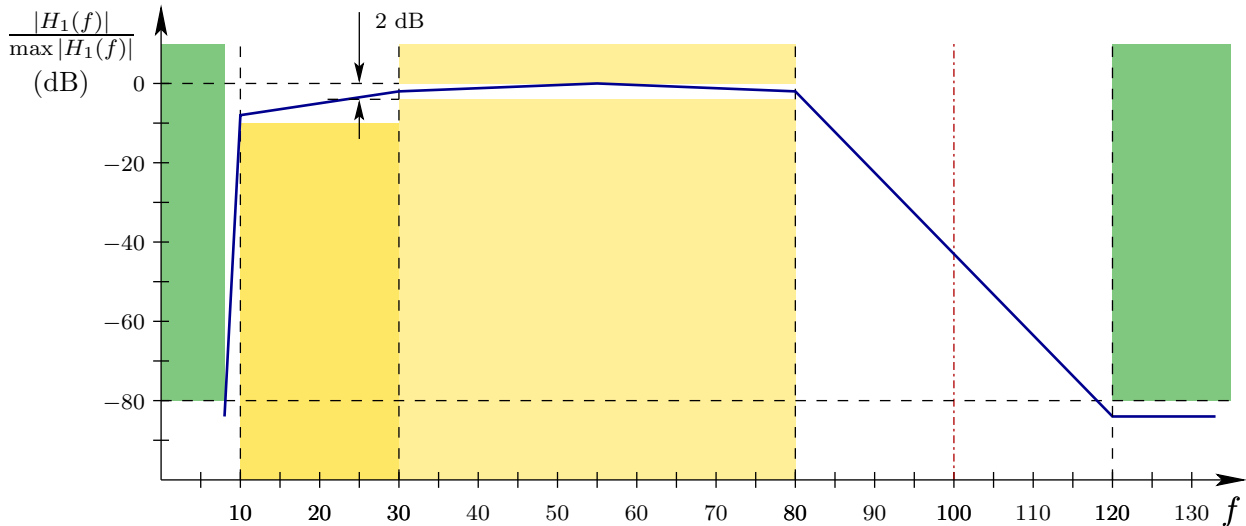

Figure 10: Filter transfer requirements modes 1 with HPF 10MHz.

### 3.6.2 Low Band: mode 1b

In this mode the low band bandpass filter is preceded with a 30 MHz highpass filter. The highpass filter can be very useful to suppress RFI signals below 30 MHz. Especially during daytime strong SW transmitters may disturb the astronomical observations. The complete filter transfer is given in Fig. 11.

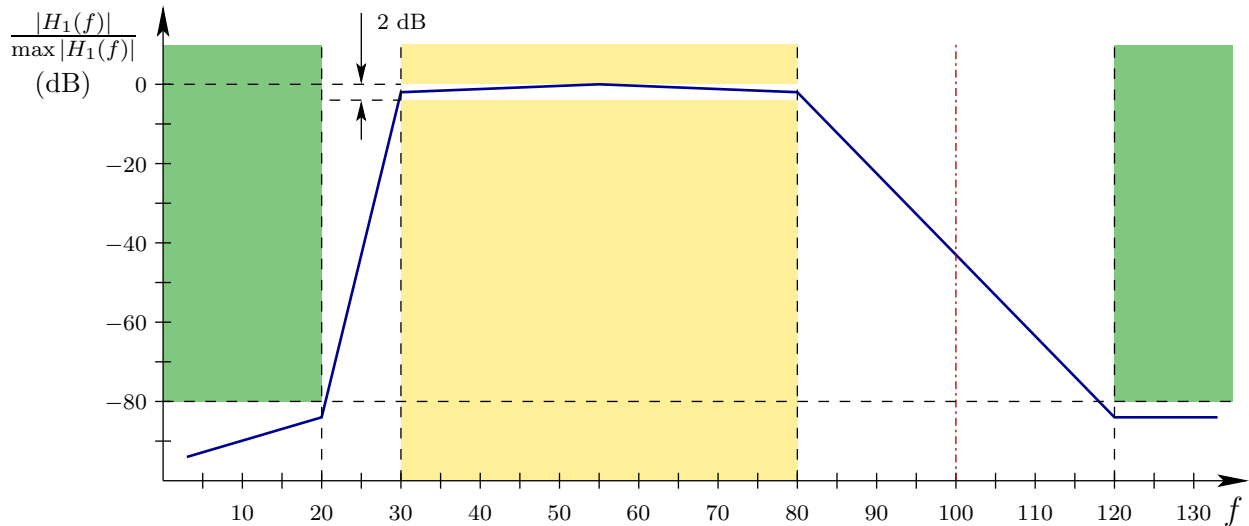

Figure 11: Filter transfer requirements modes 1 with HPF 30MHz.

### 3.6.3 High Band: mode 2

In this mode the input signal is sampled in the second nyquist zone. Below 100 MHz and above 210 MHz the signals should be attenuated to prevent aliasing. On the low side the transition band is only 10 MHz. This because the signals in the FM band need to be attenuated as much as possible. The filter transfer is shown in Fig. 12.

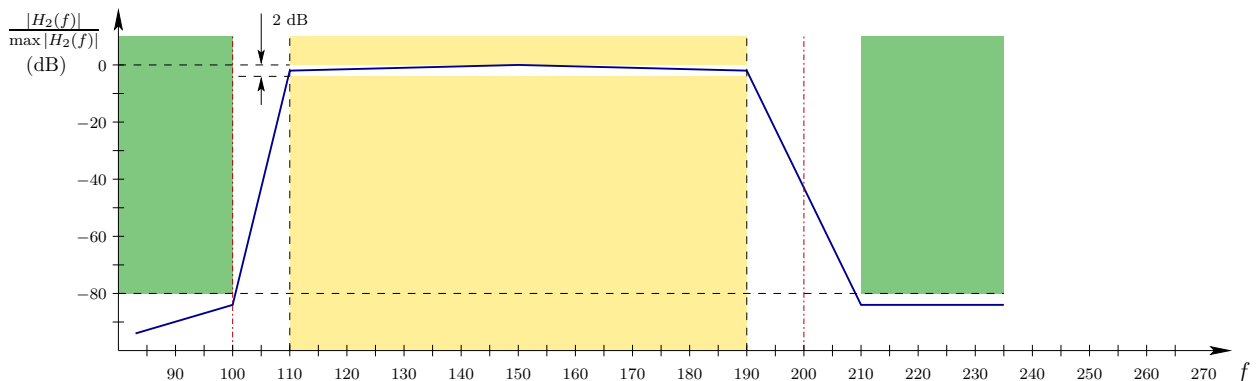

Figure 12: Filter transfer requirements modes 2.

### 3.6.4 High Band: mode 3

In this mode the input signal is also sampled in the third nyquist zone, but with a sampling frequency of 160 MHz. Below 150 MHz and above 250 MHz the signals should be attenuated to prevent aliasing. In the transition band aliasing will occur but this is no problem because this happens outside the passband. The filter transfer is shown in Fig. 13.

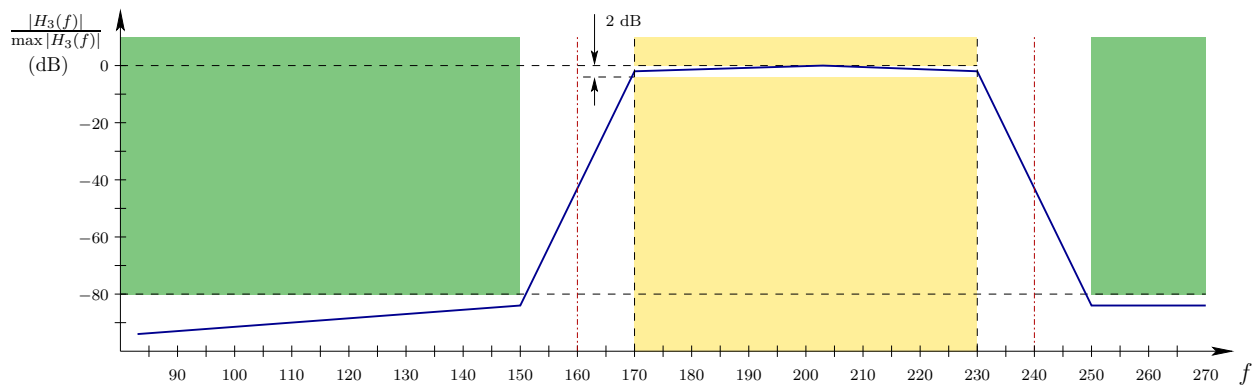

Figure 13: *Filter transfer requirements modes 3.*

### 3.6.5 High Band: mode 4

In this mode the input signal is sampled in the third nyquist zone with 200 MHz sampling frequency. Below 190 MHz and above 330 MHz the signals should be attenuated to prevent aliasing. In the transition band aliasing will occur but this is no problem because this happens outside the passband. The pass band is extended above 240 MHz to have a more flat response upto 240 MHz. The filter transfer is shown in Fig. 14.

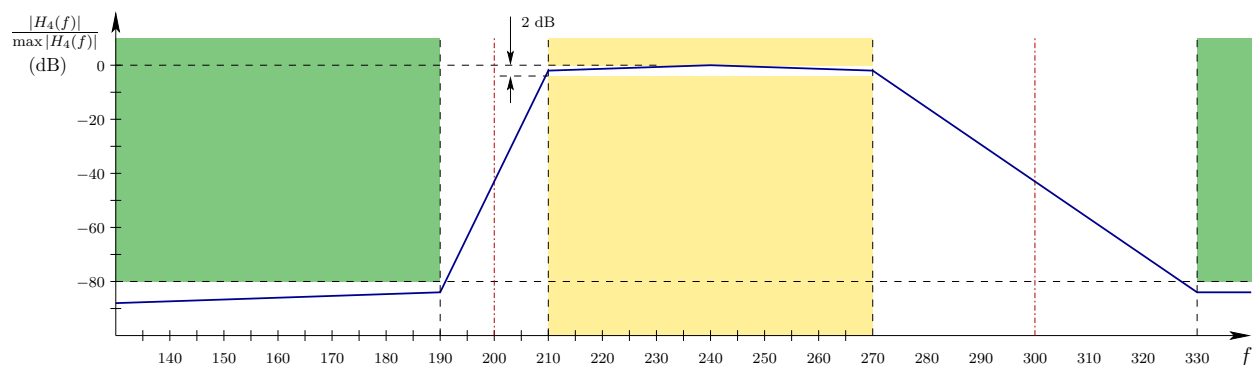



Figure 14: *Filter transfer requirements modes 4.*

Author: M.J. Norden	Date of issue: 2007-Maa-23 Kind of issue: Limited	Scope: RCU, STS Doc.nr.: LOFAR-ASTRON-SRS-014	
	Status: Draft Revision nr.: 1.2	File: <a href="http://www.lofar.org">http://www.lofar.org</a>	

### 3.7 RCU specifications

From the total receiver system calculation, the receiver specifications have been deduced (Table 4). The system noise power at the input of the A/D converter was chosen to be  $N_{ad} = 10\text{nW}$  (-50 dBm). The maximum signal level at the A/D converter before clipping may start is 40 dB above the system noise, at  $P_{stcl} = -10$  dBm. This is formulated in the System Requirements Specification SRS [3.04.01] [6] as:

*The station shall not clip the data of RFI sources with a strength up to 40 dB on top of the sky noise power. This is the whitened integrated sky noise power in at least 32 MHz bandwidth.*

So below -10 dBm at the A/D converter input, the linearity of the receiver system should meet at least the soft spurious requirement. This requirement is formulated later in this section. The linearity of the receiver will be specified using the commonly used two tone inter-modulation measurement. The maximum input level for a two tone signal is 6 dB lower then for a single tone because sometimes the amplitudes may add. So the corresponding power level of each tone should be set to  $P_{fp} = P_{fq} = -16$  dBm at the input of the A/D converter.

The second and third order two tone intercept point at the output of the RCU are respectively [1]:

$$\text{OIP2} = P_{RFI}(f) + \Delta_2, \quad (\text{dBm}) \quad (27)$$

$$\text{OIP3} = P_{RFI}(f) + \frac{\Delta_3}{2}, \quad (\text{dBm}) \quad (28)$$

where  $\Delta_2$  and  $\Delta_3$  represents the distance between  $P_{RFI}$  and the intermodulation products  $P_{IM}$  as shown in Fig. 15.

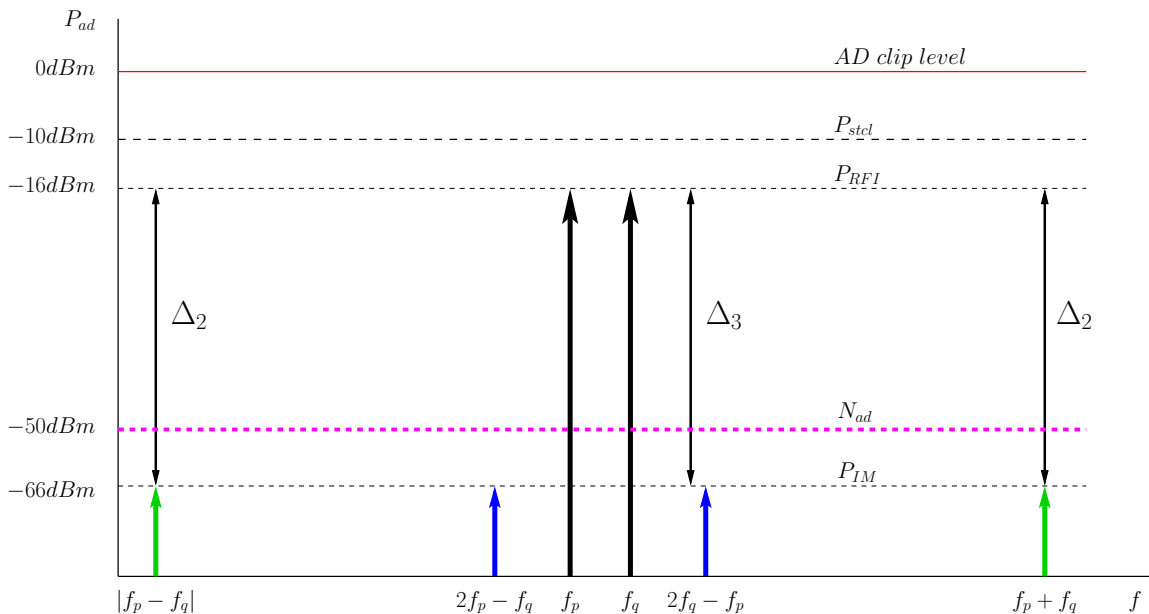



Figure 15: Two tone intermodulation products



Author: M.J. Norden	Date of issue: 2007-Maa-23 Kind of issue: Limited	Scope: RCU, STS Doc.nr.: LOFAR-ASTRON-SRS-014	
	Status: Draft Revision nr.: 1.2	File: <a href="http://www.lofar.org">http://www.lofar.org</a>	

For linearity the soft spurious requirement has been adopted as the target requirement SRS [3.04.03] [1, 7].

*The soft spurious requirement is, where the integrated power of all spurious signals in the selected band shall remain 10dB below the integrated noise power of the selected frequency band after whitening the sky noise.*

With (27,28),  $P_{RFI} = -16$  dBm and the intermodulation power level  $P_{IM} = -66$  dBm the required OIP2 and OIP3 to meet the soft spurious requirement are 34 dBm respectively 9 dBm. For mode 2,3 and 4 the second order inter-modulation products will fall outside the frequency band of interest. The analog filters will attenuate these inter-modulation products. For low band mode 1 the second order inter-modulation products can fall inside the frequency band of interest. This makes mode 1 the most difficult section for linearity. This is solved in the design with more attenuation in front of the first amplifier and a more linear amplifier. The noise figure will become higher but is within specification (see section 3.1).

Table 4: Receiver Specifications

Item	LB: Mode 1	HB: Mode 2	HB: Mode 3	HB: Mode 4	Unit
Input noise density	-151	-148	-152	-155	dBm/Hz
Input noise power	-72	-69	-74	-77	dBm
Output noise density	-129	-129	-128	-128	dBm/Hz
Output noise power	-50	-50	-50	-50	dBm
System bandwidth	80	80	60	60	MHz
Frequency Range	10-90	110-190	170-230	210-270	MHz
Sampling Frequency	200	200	160	200	MHz
Available Gain	22	19	24	27	dB
NF	11.9	13.4	8.9	6.4	dB
Noise Temperature	4163	6016	1975	959	Kelvin
One tone input level (max.)	-32	-29	-34	-37	dBm
Two tone input level (max.)	-38	-35	-40	-43	dBm
OIP2	34	34	34	34	dBm
OIP3	9	9	9	9	dBm
IIP2	12	15	10	7	dBm
IIP3	-13	-10	-15	-18	dBm

Author: M.J. Norden	Date of issue: 2007-Maa-23 Kind of issue: Limited	Scope: RCU, STS Doc.nr.: LOFAR-ASTRON-SRS-014	
	Status: Draft Revision nr.: 1.2	File: <a href="http://www.lofar.org">http://www.lofar.org</a>	

### 3.8 Control RCU-II

The receiver unit is controlled and monitored by the Local Control Unit (LCU). In a LOFAR station the LCU is the control part of Monitor and Control (MAC). The LCU controls the receiver unit via the Remote Station Processing (RSP) board [8]. The interface is via I<sup>2</sup>C bus and protocol. On the receiver board an FPGA is used to control the switches, power supplies and attenuator. The first 16 bits are used to control the receiver hardware. The remaining 8 bits are used by the FPGA or reserved. The allocation of the control bits can be found in Table 5.

Table 5: RCU-II control selection

Bit	Function	Remark
0	LBL-EN	supply LBL antenna on (1) or off (0)
1	LBH-EN	supply LBH antenna on (1) or off (0)
2	HB-EN	supply HBA on (1) or off (0)
3	BANDSEL	low band (1) or high band (0)
4	HB-SEL-0	HBA filter selection (see Table 6)
5	HB-SEL-1	HBA filter selection (see Table 6)
6	VL-EN	low band supply on (1) or off (0)
7	VH-EN	high band supply on (1) or off (0)
8	VDIG-EN	ADC supply on (1) or off (0)
9	LB-SEL-0	LBA input selection (see Table 7)
10	LB-SEL-1	HP filter selection (see Table 7)
11	ATT-CNT-4	on (1) is 1dB attenuation
12	ATT-CNT-3	on (1) is 2dB attenuation
13	ATT-CNT-2	on (1) is 4dB attenuation
14	ATT-CNT-1	on (1) is 8dB attenuation
15	ATT-CNT-0	on (1) is 16dB attenuation
16	PSRG	on (1), off (0) [internal in the chip]
17	RESET	
18	TBD	reserved
19	TBD	reserved
20	TBD	reserved
21	TBD	reserved
22	TBD	reserved
23	TBD	reserved

Author: M.J. Norden	Date of issue: 2007-Maa-23 Kind of issue: Limited	Scope: RCU, STS Doc.nr.: LOFAR-ASTRON-SRS-014	
	Status: Draft Revision nr.: 1.2	File: <a href="http://www.lofar.org">http://www.lofar.org</a>	

In the high band the required bandpass filter can be selected using two bits. The three selectable filters are given in Table 6.

Table 6: HB filter selection

HB-SEL-1	HB-SEL-0	Function
0	0	210-270 MHz
0	1	170-230 MHz
1	0	110-190 MHz
1	1	all off

For the low band two bits are available. One to select the antenna input and the other to select the highpass cut-off frequency. In Table 7 the available options are tabulated.

Table 7: LB filter selection

LB-SEL-1	LB-SEL-0	Function
0	0	LBL input with 10 MHz HPF
0	1	LBH input with 10 MHz HPF
1	0	LBL input with 30 MHz HPF
1	1	LBH input with 30 MHz HPF

The FPGA is not only used to control the RCU, but can also be used to test the interconnection between receiver and RSP board at maximum datarate (200Msample/sec). For this test a pseudorandom generator is implemented in the FPGA. On the RSP a Bit Error Rate (BER) test can be performed. The default mode for the FPGA is transparent buffer mode.

### 3.8.1 HBA control modem

A HBA tile consists of 16 X-polarization dipole antennas and 16 Y-polarization dipole antennas. Each of these 16 antennas is delayed appropriately and then summed to provide a single X-polarization signal output and a single Y-polarization signal output. This implements the HBA beam former. Each beam former delay is set via an I<sup>2</sup>C command. The interface is between LCU and RCU and goes via the RSP board. The interface between RCU and HBA tile is via a low frequent modulated signal over a coax cable. The interface is drawn in Fig. 16.

Author: M.J. Norden	Date of issue: 2007-Maa-23 Kind of issue: Limited	Scope: RCU, STS Doc.nr.: LOFAR-ASTRON-SRS-014	
	Status: Draft Revision nr.: 1.2	File: <a href="http://www.lofar.org">http://www.lofar.org</a>	

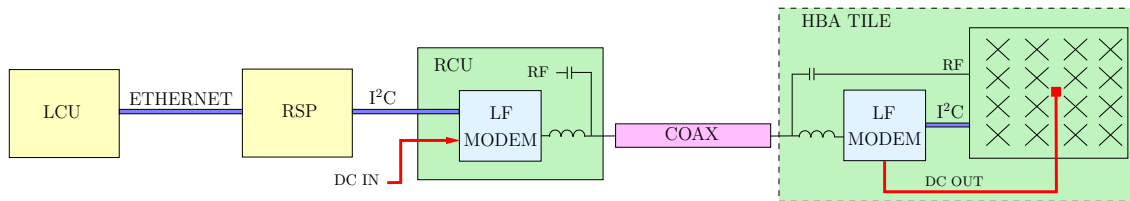

Figure 16: *HBA control interface*

Not only the control signal, but also the power supply goes via the coax cable to the HBA. One HBA tile is connected with two receivers, one per polarization. Only one receiver is equipped with a LF modem, because it can serve the entire HBA tile. The other receiver delivers only power to the HBA. The DC supply for the HBA is designed for 48 V/1 A per receiver.

The HBA control modem is integrated on the receiver unit. With a jumper the modem or power supply function can be selected. The X polarization is used for power distribution and the Y polarization for control. The LF modem details are depicted in Fig. 17.

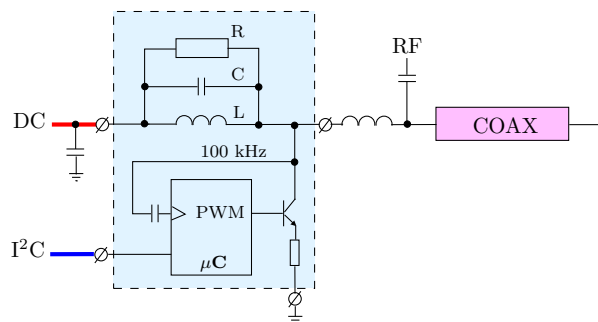



Figure 17: *LF modem*

The communication is half duplex and allow a maximum bit rate of 30 kbps. The modem is build around a PIC16F87 controller. The modulation and demodulation function is implemented in the firmware of this microcontroller. More detailed information about the implementation and measurement results of the HBA modem can be found in [9]. To reduce EMI during observation, both modems can be placed in sleep mode. The modem in the RCU can be woken up by I<sup>2</sup>C access and the HBA modem can be woken up by the presence of the carrier. A more detailed description of the HBA control design and communication protocol can be found in [10].

Author: M.J. Norden	Date of issue: 2007-Maa-23 Kind of issue: Limited	Scope: RCU, STS Doc.nr.: LOFAR-ASTRON-SRS-014	
	Status: Draft Revision nr.: 1.2	File: <a href="http://www.lofar.org">http://www.lofar.org</a>	

### 3.9 Power supply requirements

The LOFAR receiver system requires three main supply voltages (5 V, 8 V and 48 V). The total power consumption of one receiver, one HBA, and one polarization of the LBA is about 43 W<sup>2</sup>. This is a worse case figure assuming that both HBA and LBA are powered. The power dissipation of a single receiver unit without antenna is about 4.5 W. The power supply requirement can be found in Tabel 8.

Table 8: power supply requirement

Power supply [V]	Current [mA]	Power [W]
5	650	3.25
8	500	4
48	730	35

The 5 V supply (VDD-IN) is split in 3.3 V, 2.5 V and 1.2 V. The power supply split is done with linear DC/DC regulators. The total power consumption of the 5 V supply voltage is about 3.25 W. An estimation of the power consumption is given in Table 9.

Table 9: 5V supply voltage (VDD-IN)

Label	Function	Voltage [V]	Current [mA]	Power [mW]
VCC-ADC	AD9430 (analog A/D)	3.3	380	1254
	AD8351 (buffer amp.)	3.3	30	100
VCC-3V3	AD9430 (digital A/D)	3.3	60	200
	MC100EP16 (clock buf.)	3.3	30	100
	LFEC1E-ST144 (FPGA)	3.3	40	140
VCC-2V5	LFEC1E-ST144 (FPGA)	2.5	80	200
VCC-1V2	LFEC1E-ST144 (FPGA)	1.2	25	30

The 8 V power supply (VCC-IN) is used to supply the LBA. At the antenna side a voltage of about 7 V is required. The DC loss in 200 m coax-9 and bias-T's is about 1 V. The RF amplifiers in the LB and HB analog receiver chain are biased with 6V. The voltages are made with two separate linear DC/DC regulators. The regulators can be switched on and off to save power and to gain more isolation is the unused signal path.

<sup>2</sup>The power dissipation of the HBA and the LBA is external and should not be accounted when calculating the air conditioning capacity.

Author: M.J. Norden	Date of issue: 2007-Maa-23 Kind of issue: Limited	Scope: RCU, STS Doc.nr.: LOFAR-ASTRON-SRS-014	
	Status: Draft Revision nr.: 1.2	File: <a href="http://www.lofar.org">http://www.lofar.org</a>	

The buffers to control the RF switches are supplied with 5 V. The higher the voltage the more linear the switches are. The total power consumption of the 8 V supply voltage is about 3.7 W. An estimation of the power consumption is given in Table 10.

Table 10: 8V supply voltage (VCC-IN)

Label	Function	Voltage [V]	Current [mA]	Power [mW]
LBA	Supply for LBA	8.0	200	1600
VCC-LOW	Low Band RF amp.	6.0	150	900
VCC-HIGH	High Band RF amp.	6.0	130	780
VDD-SW	RF switch + att.	5.0	20	100

The 48 V power supply is only used by the HBA. The HBA tile operates at 48 V/0.73 A (35 W). The 48V is converted to 7V in the HBA summator. This to reduce the current on the coax cable and therefore the power dissipation in the cable. Assuming 100 m coax-9 with 26  $\Omega$ /km and 0.73 A per cable yields  $0.73 \cdot 2.6 = 1.4$  V loss. The loss in power is  $0.73^2 \cdot 2.6 = 1.4$  W loss, so about four percent of the power is lost in the cable.

Table 11: 16V supply voltage (VCC-HBA)

Label	Function	Voltage [V]	Current [mA]	Power [W]
HBA	Supply for HBA	48.0	730	35

## A Control RCU-I

Table 12: RCU-I control selection

Bit	Jumper	Function	Remark
0	JP2	LBA-ENABLE	supply LBA on (1) or off (0)
1	JP3	HBA-ENABLE	supply HBA on (1) or off (0)
2	JP4	BANDSEL	low band (0) or high band (1)
3	JP5	FILSEL-0	HBA filter selection (see table)
4	JP6	FILSEL-1	HBA filter selection (see table)
5	JP8	VL-ENABLE	low band supply on (1) or off (0)
6	JP7	VH-ENABLE	high band supply on (1) or off (0)
7	JP9	VDDVCC-ENABLE	supply AD and buffer on (1) or off (0)

Table 13: RCU-I control selection

FILSEL-1	FILSEL-0	Function
0	0	110-190 MHz
0	1	170-230 MHz
1	0	210-270 MHz
1	1	all off

## B Cable loss: Coax-9

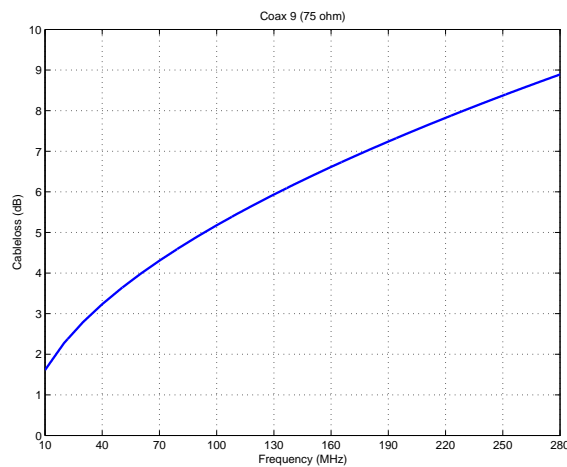
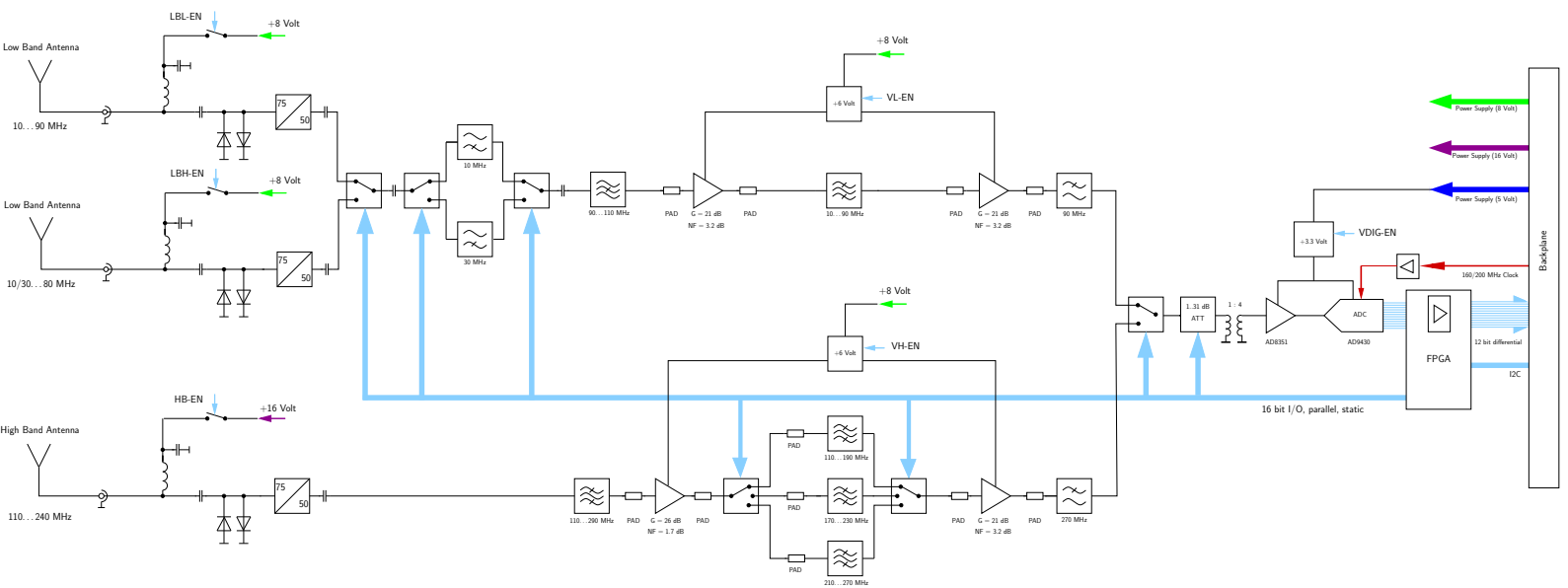

Figure 18: The cable loss for 100 meter coax 9: 10-280MHz

Author: M.J. Norden	Date of issue: 2007 -Maa-23	Scope: RCU, STS
Status: Draft	Kind of issue: Limited	Doc.nr.: LOFAR-ASTRON-SRS-014
Revision nr.: 1.2	File: <a href="http://www.lofar.org">http://www.lofar.org</a>	



## C Block diagram RCU-II





Author: M.J. Norden	Date of issue: 2007-Maa-23 Kind of issue: Limited	Scope: RCU, STS Doc.nr.: LOFAR-ASTRON-SRS-014	
	Status: Draft Revision nr.: 1.2	File: <a href="http://www.lofar.org">http://www.lofar.org</a>	

## References

- [1] G.W. Kant. LOFAR Intermodulation Analysis and Specification. Technical Report LOFAR-ASTRON-AWP-001, ASTRON, Dwingeloo, the Netherlands, November 2003.
- [2] G.W. Schoonderbeek and M.J. Norden. RCU II Measurement Report. Technical Report LOFAR-ASTRON-RPT-059, ASTRON, Dwingeloo, the Netherlands, Sept 2005.
- [3] A.W. Gunst and G.W. Kant. Balancing Bits and Bandwidth for the A/D Converters of LOFAR. Technical Report LOFAR-ASTRON-MEM-121, ASTRON, Dwingeloo, the Netherlands, November 2003.
- [4] A.W. Gunst. Effective number of bits in A/D converters. Technical Report LOFAR-ASTRON-MEM-066, ASTRON, Dwingeloo, the Netherlands, November 2002.
- [5] A.W. Gunst. LOFAR Digital Filter Requirements. Technical Report LOFAR-ASTRON-MEM-162, ASTRON, Dwingeloo, the Netherlands, October 2004.
- [6] A. Huijgen. Remote Station Subsystem Requirements Specification. Technical Report LOFAR-ASTRON-STS-12, ASTRON, Dwingeloo, the Netherlands, December 2004.
- [7] C.M. de Vos. Some notes on LOFAR IP2/IP3 Specification. Technical Report LOFAR-ASTRON-MEM-132, ASTRON, Dwingeloo, the Netherlands, December 2003.
- [8] A. Huijgen. Remote Station Architectural Design Document. Technical Report LOFAR-ASTRON-ADD-13, ASTRON, Dwingeloo, the Netherlands, December 2004.
- [9] P. Riemers. A CONTROL LINE FOR LOFAR-HBA. Technical Report Report ASTRON-LOFAR-HBA, ASTRON, Dwingeloo, the Netherlands, Januari 2006.
- [10] E. Kooistra. Design specification for the HBA control in a Remote Station. Technical Report LOFAR-ASTRON-MEM-175, ASTRON, Dwingeloo, the Netherlands, April 2005.