

LOFAR Engineering/Roll Out Update

André W. Gunst

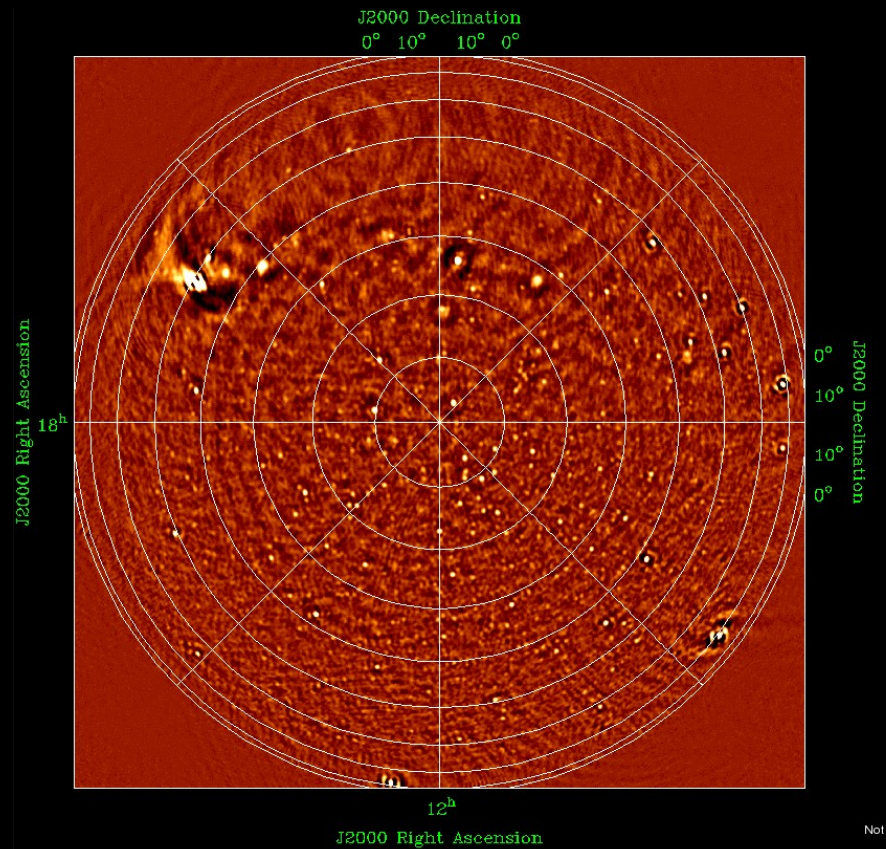

LOFAR20 Step 1

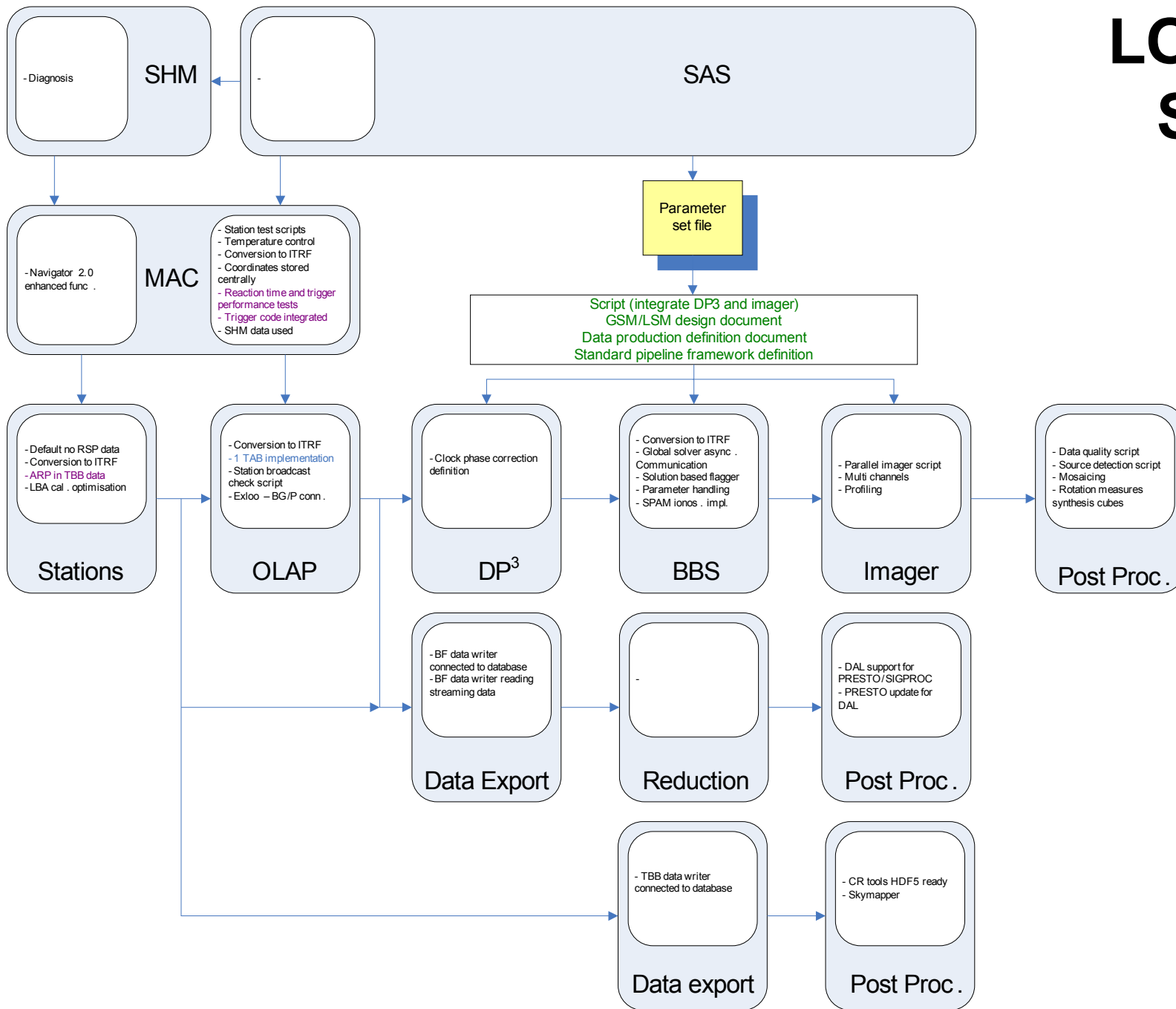

- ARP in TBB
- Raw data capture mode
- CImager
- PVSS databases in field
- CR tools TBB HDF5 ready

- Station equipment
- Central equipment
- From proto → production
- More secure network

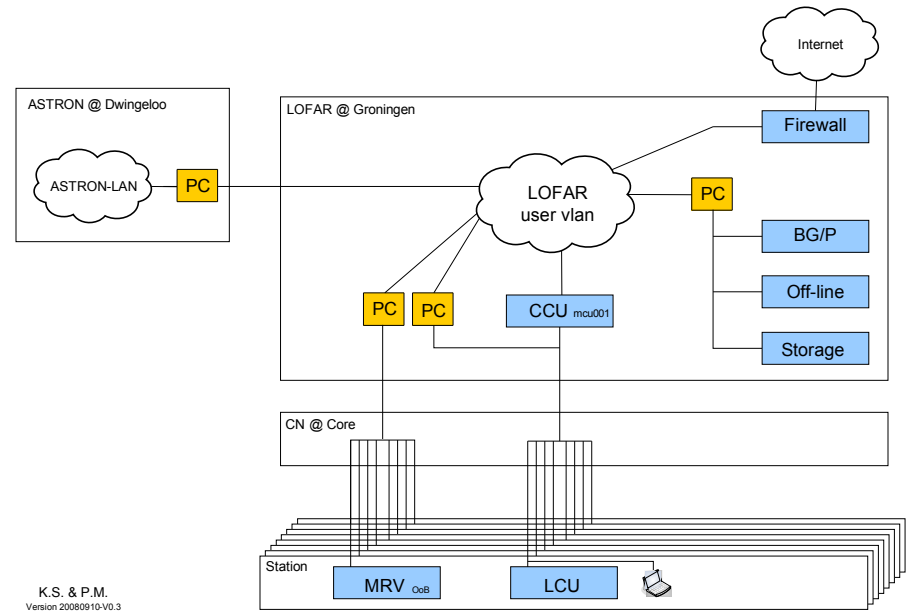

- Domains astron.nl & lofar.nl separated
- LCUs not directly accessible
- SHM server, MAC/SAS machines to Groningen

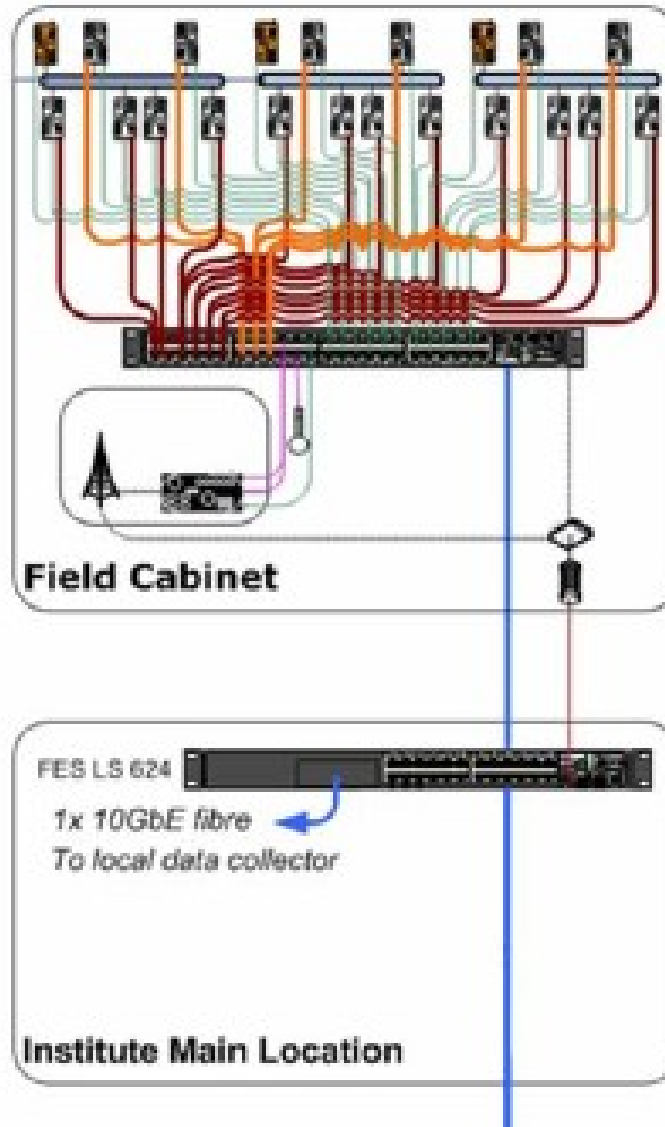

On behalf of Yde Koopman

