



LOFAR Data Preparation using Default Pre-Processing Pipeline

V.N.Pandey, Adriaan Renting, Joris Van zWieten
Marcel Loose, and Ger de Bruyn
Kapteyn Institute/ASTRON

February 10th, 2009
LOFAR Data Processing School, Dwingeloo

Outline

- 1 **LOFAR processing chain – Standard Imaging Pipeline**
- 2 **Role of DPPP (or DP³)**
- 3 **DPPP - Capabilities**
- 4 **DPPP – More aspects, What we do today**
- 5 **Summary**

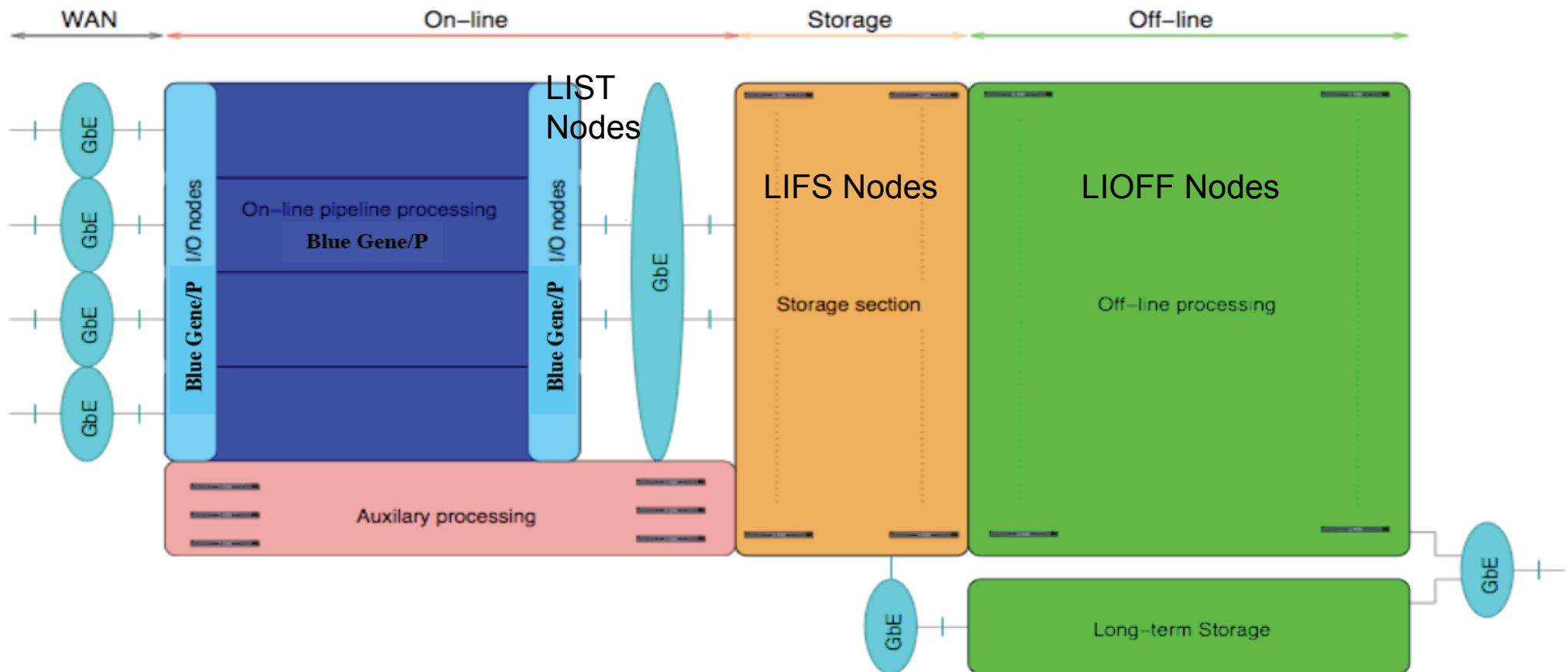

- **BG/P** *Data reception, transpose, correlation, beam-forming, de-dispersion*
- **Storage system** *Short term storage of data, ~1 PByte, >100Gbps I/O*
 - **Offline cluster** *Calibration, data products, off-line analysis, ~1000 nodes*

Offline Automatic Processing – DP³ Role

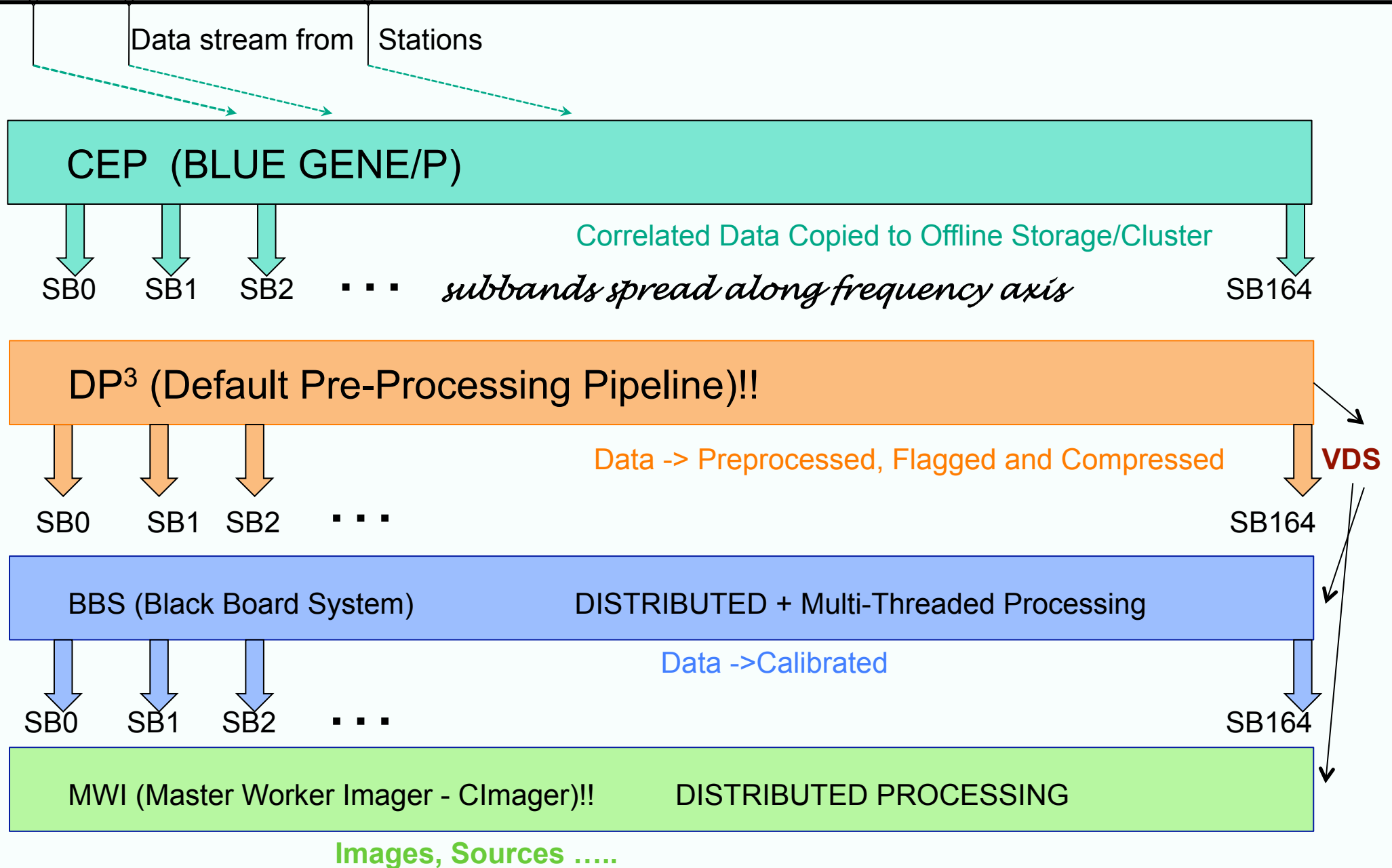

DP³ Capabilities

Default Pre-Processing Pipeline (DP³)

- 1 - What does it do? – Aims
- 2 - How does it work? - Implementation

DPPP- AIM/Objective

Carry out all Pre-Calibration common default steps in an efficient way.

1. Phase Correction due to diff clocks at stns
2. Sub-Band Pass correction
3. Global Band Pass correction
4. Flagging – Pre-Flags and Algorithm based
5. Compression along Frequency Axis
6. Compression along Time Axis
7. Combining Different Sub Bands into a single Mset.

H
N
H
H
G
R
A
H
H
A

A
H
H
R
A
P
H
A

Software

Source Code (C++)
Run Script (Python)

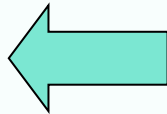

Parameter Set File, Cluster Description files

- Runs in a Distributed way on different compute nodes (Not to be tried today)
Each Measurement Set processed on one processor
- Reads the Measurement set only once for all steps

DP³ – Capabilities

1. Phase Correction due to clock drifts

- Correct for phase differences introduced due to different clocks at stations
- Predetermined Table of corrections to be applied
- At this stage exact algorithm is not clear - TBD

2. Sub-Band Bandpass correction

- Bandpass shape within each Sub-band due to Polyphase filter bank
- Predetermined table as a function of frequency
- Already implemented at CEP (Blue Gene) so no more required in DP³
- In case we need improvements may be implemented.

3. Global Band Pass correction

- Global Bandpass correction due to Antennae response to different Frequency
- Predetermined table as a function of frequency
- Once estimated accurately using BBS global solver would be implemented.

Generic Implementation to have multiple tables of corrections in one step

4. Flagging

APRIOR Knowledge Based

REGION CUM CRITERIA APPROACH (under progress!!)

REGION: Time, Freq, baseline, Correlation, Direction

CRITERIA: Any condition a pixel in the region satisfies

- Build a mask using
 - existing flags
 - nan (0/0), infinite
 - channel selection
 - antenna
 - baseline length

More options to be decided

Advantage: Provides region specific solution

Ex Threshold a function of correlation, baseline etc.

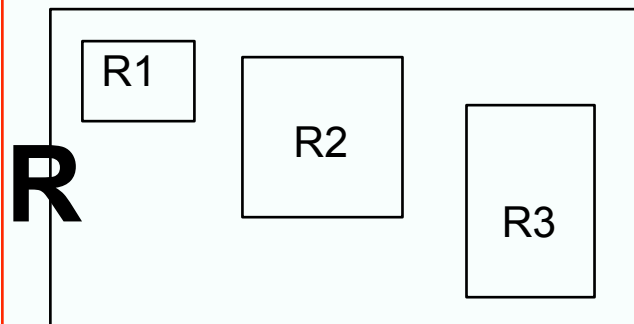

R1- C1, C2,

R2 – C1, C6...

ALGORITHM BASED

- Generic code to accommodate
 - different flagging algorithms
 - multiple flaggers
 - Currently uses
 - Amplitude thresholding
 - MAD flagger (Hampel filter)
(Two dimensional – freq & time)
 - Mirroring on the ends- avoids edge effects
 - Can run on data column desired
 - Multiple flaggers implemented
-
- Satisfactorily results on actual data

Frequency ->

Frequency ->

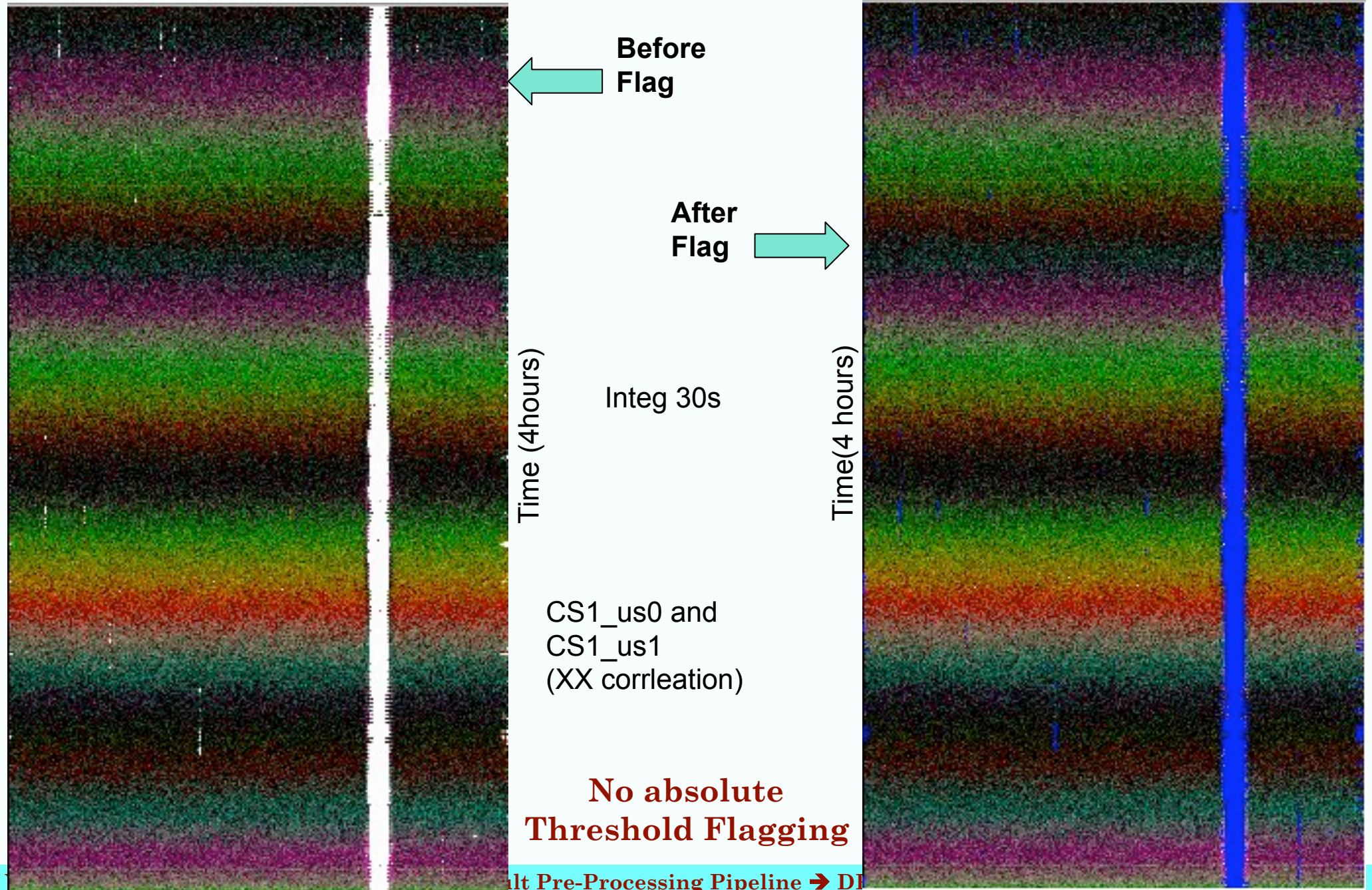

Frequency ->

Frequency ->

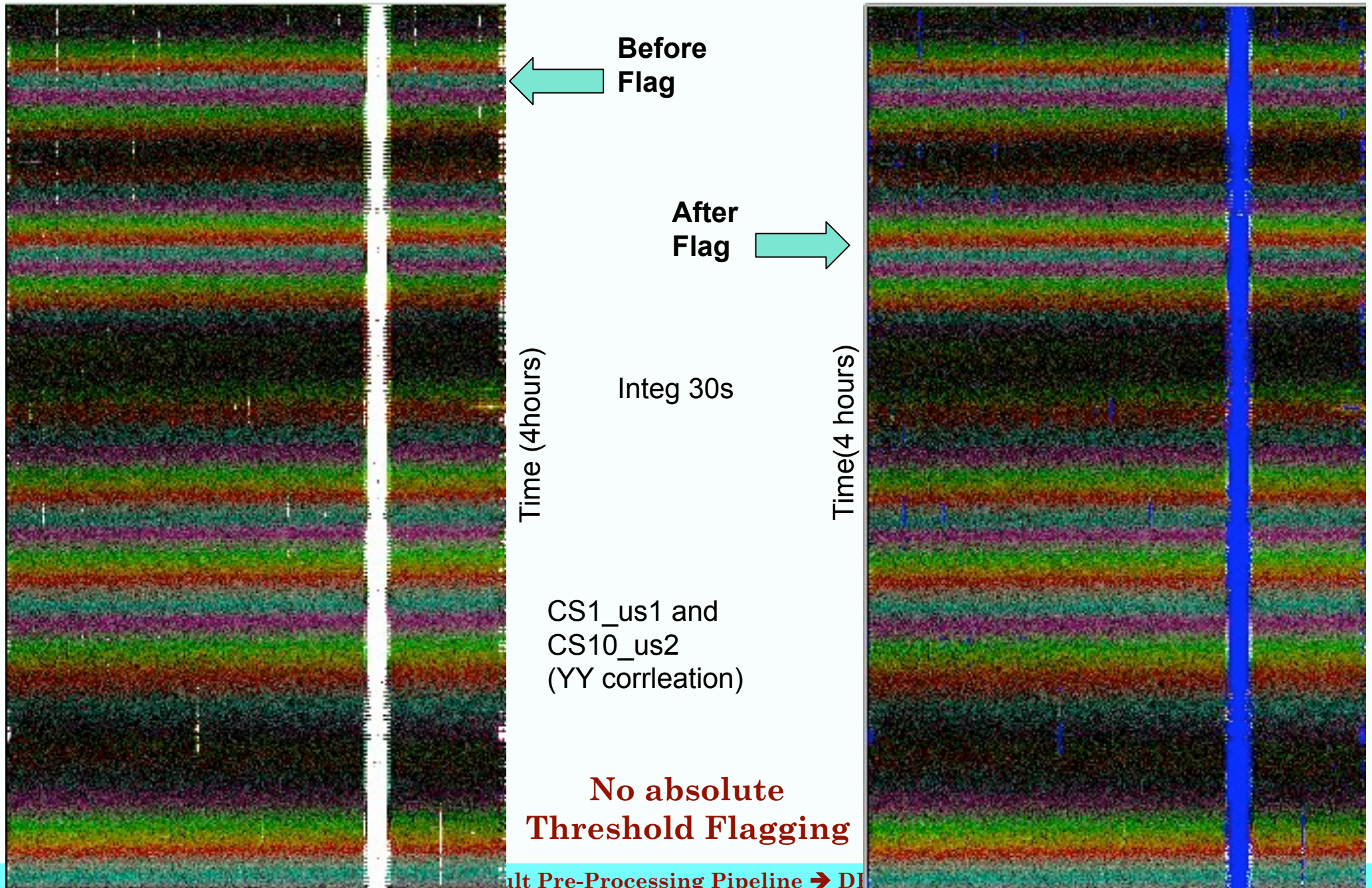

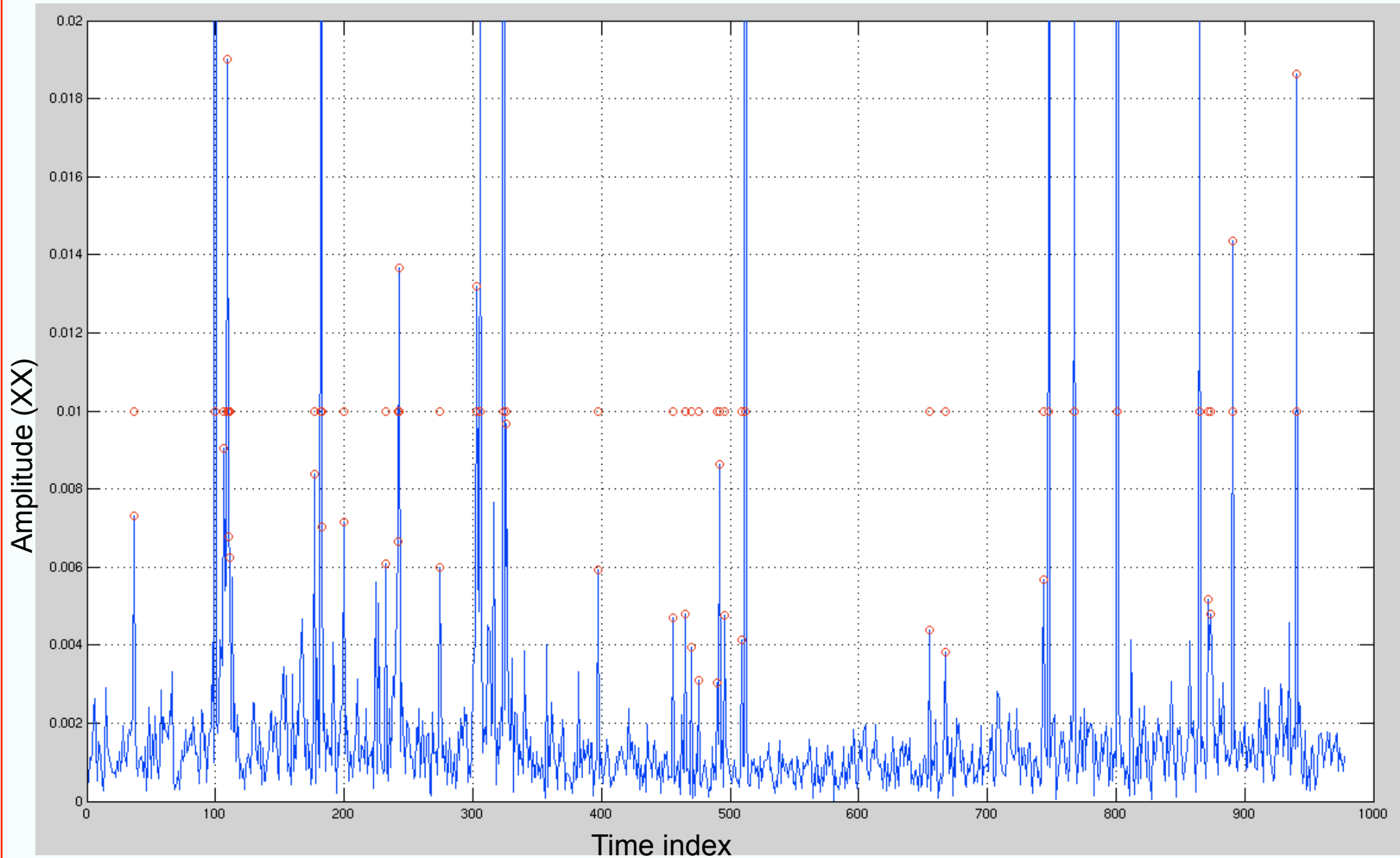

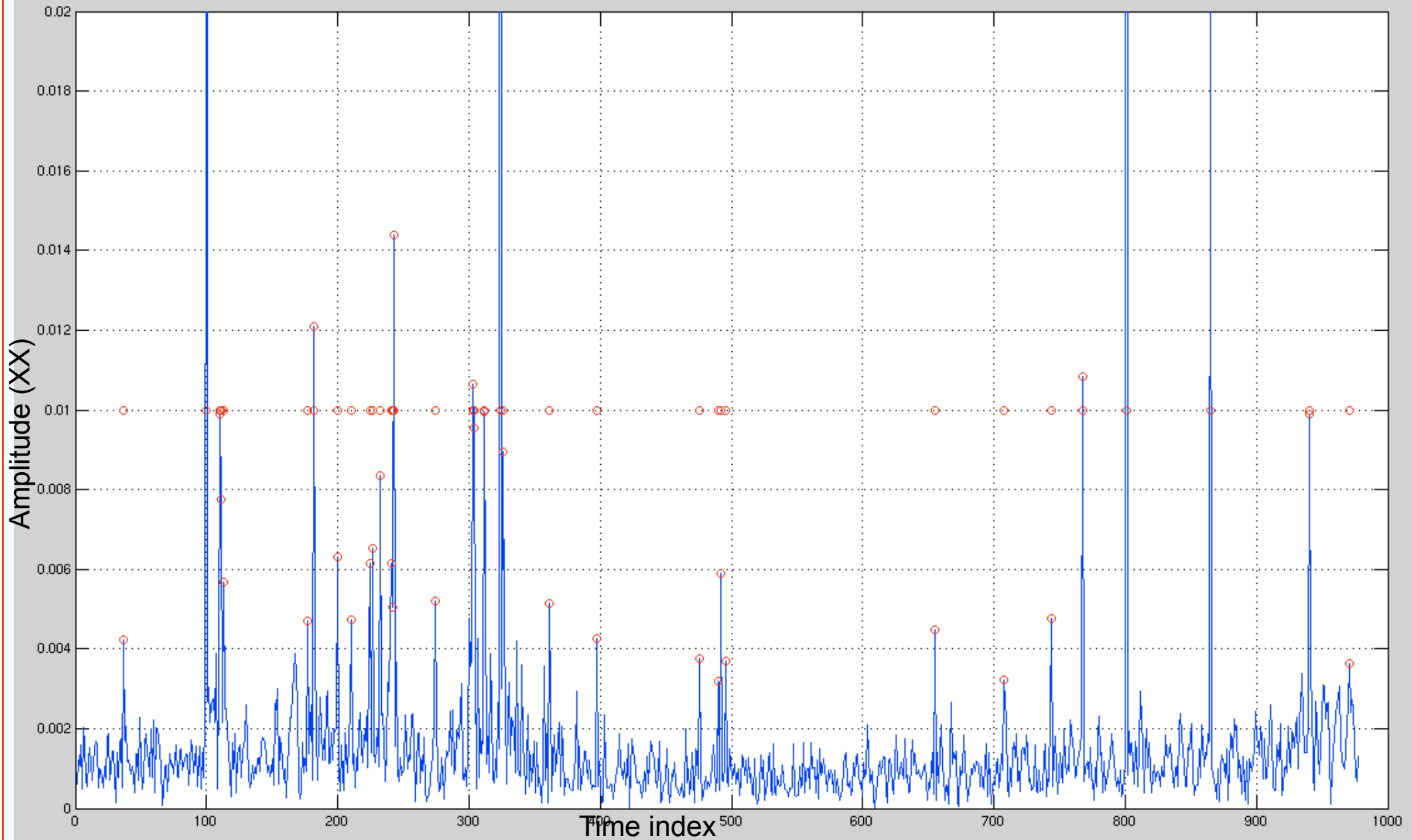

5. Compression along frequency axis

6. Compression in time

- Uncompressed Data - >> 100 Terabytes/Day
- Implemented together, any one may be selected or switched off
- Compressed pixel = mean (unflagged values)
- Weight column appropriately modified depending on number of pixels flagged
- Time and Frequency of compressed (Averaged pixel) **
- Multiple stage compression allowed

Performance of DP³

- >99% CPU usage most of the time
- On 24hr data set, 30s integration, 256 channels
15x15 window : 4hours (2.0GHz processor)
Matlab : ~40 hours (uncompiled run)

Hands on DP³ today

Exercise-05-DPPP

1. Pick up an Actual observation with LOFAR CS1
2. Run DP³ for RFI Detection/Flagging
3. Look at how effective is the flagging
4. Do compression along time, frequency
5. Inspect the data

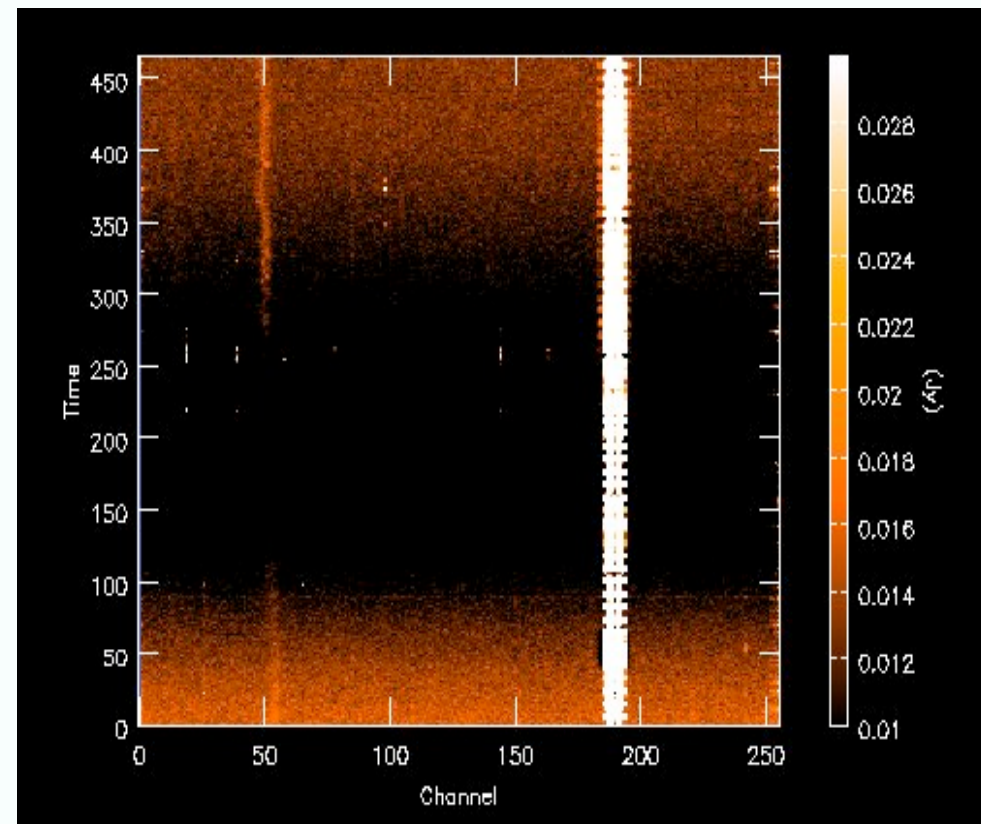
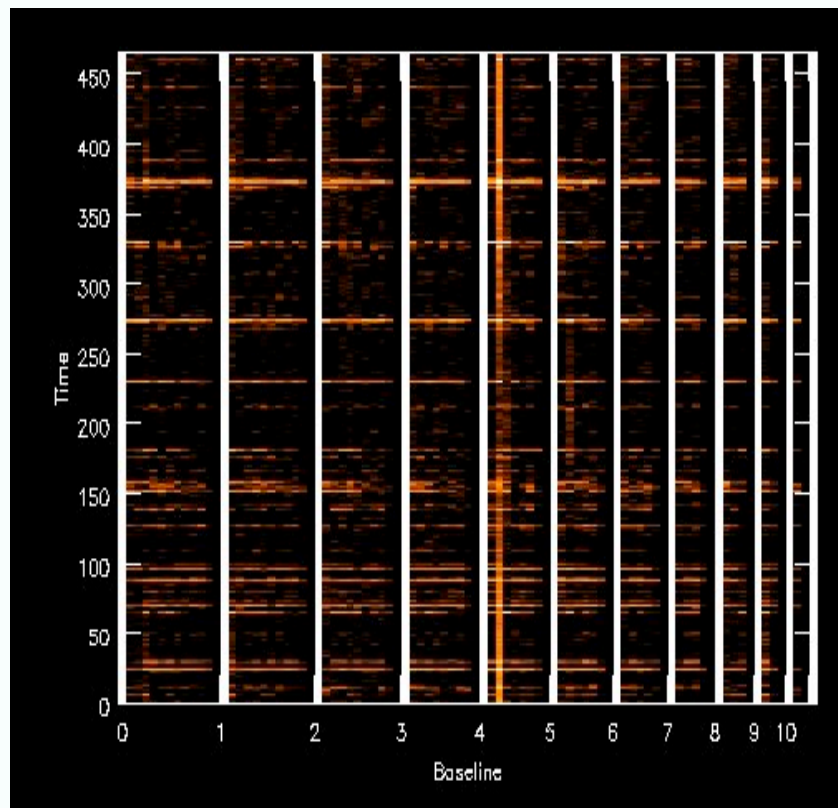

Channels

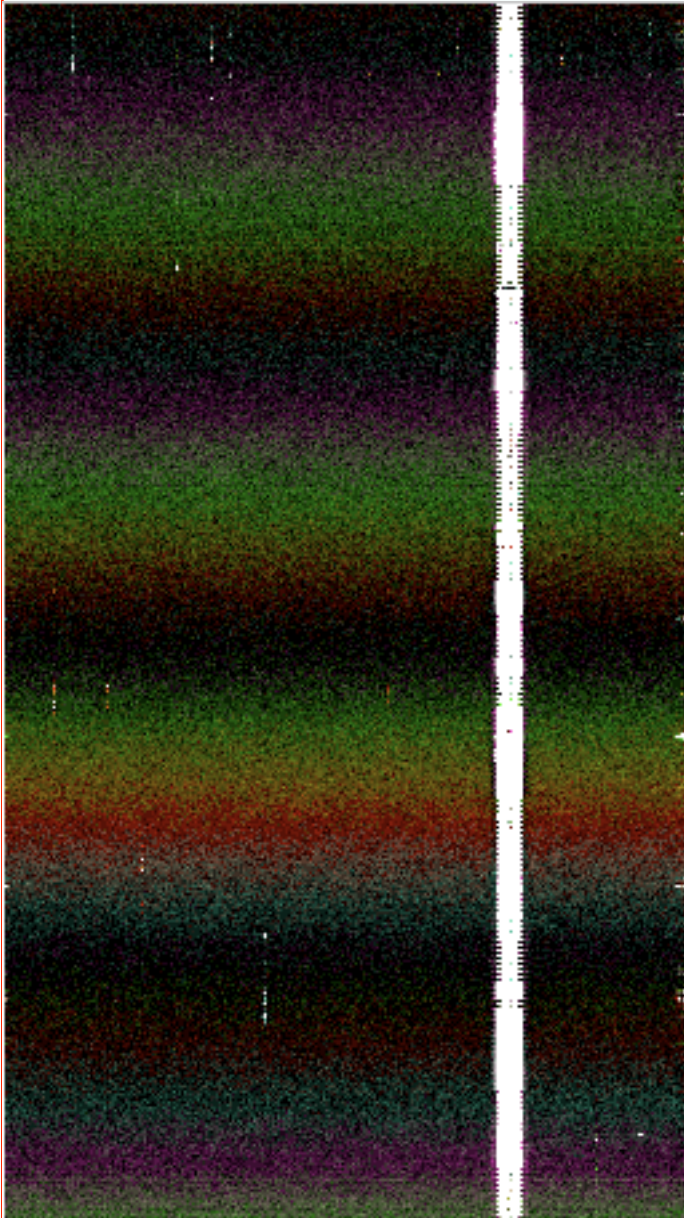

L2008_9315_SB12.MS
39.45MHz, 195KHz wide
256 channels, each channel 0.76KHz

T
I
M
E

Channels

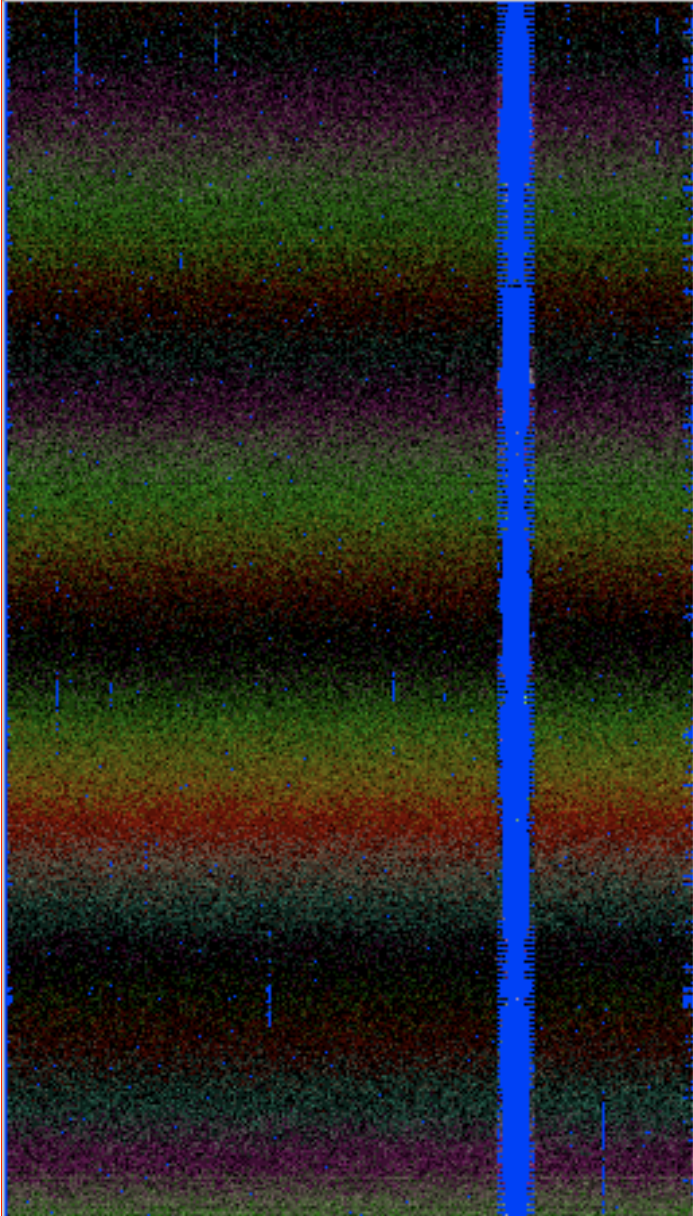

T
I
M
E

Conclusions -Open issues/ Next steps

- Complete DP³ Pipeline has been tested, works successfully.
- Compressed sub-bands passed successfully via MW Imager.
- Computational Speed improved – steps integrated in one.
- Integrated in the offline Pipeline.
- Code Generic to support different and multiple flaggers
- and Multiple levels of compression.
- Time and frequency of Averaged pixels in compressed MS under discussed.
- More computational bench mark tests.
- Efficient flagging criteria for mask to be discussed.
- Regularly used from ?
- Hands on Session ☺

Discussions??
!! Thank you !!



LOFAR User Software Group

Trace: » [index](#) » [workshops](#) » [2009-02_processing_school](#) » [hands-on_exercises](#)

PROJECT

- News & Changes (Archive)
- Key Science Projects
- LOFAR Network
- Glossary
- USG personnel

DEVELOPMENT

- Getting started
- General information
- Code repository
- Environment & Tools
- Supported platforms
- Testing
- Sample data sets

SOFTWARE

- Packages and Tools
- Libraries
- Visualization
- Downloads
- User contributions

DOCUMENTATION

- Workshops
- LOFAR Data products
- Minutes from meetings
- Work packages
- Presentations
- Pictures
- Wiki help

RELATED PAGES

- USG CODE
- USG DOXYGEN
- USG WEBSTATS
- USG FORUM
- LOFAR WEBSITE
- LOFAR WIKI

LOFAR Data Processing School :: Hands-on exercises

The workshop will mainly utilize some of the LOFAR offline cluster nodes to run the exercises. These machines are named "lioff0XX" where X goes from 21-29. To reach these machines, you have to first login to listfen. So ssh into listfen and then ssh into one of the working nodes.

On these machines, there is an area set aside named "/data/lofarschool" where all the exercises will be stored. Within that directory there will be two sub-directories, one called "users" which the students will use as working areas and one called "data" which will contain subdirectories for each of the exercises:

```
/data/lofarschool
|-- data
|   |-- Exercise_01
|   |-- Exercise_02
|   |-- Exercise_03
|-- users
```

Each directory subdirectory will contain all the inputs, expected outputs, scripts, logfiles, instructions, etc associated with a given exercise, i.e. :

```
lioff023:/data/lofarschool/data/Exercise_01> ll
total 8
-rw-r--r-- 1 wise wise 0 2009-02-04 19:26 example_01.log
-rw-r--r-- 1 wise wise 0 2009-02-04 19:26 example_01.py
drwxr-xr-x 2 wise wise 4096 2009-02-04 19:25 inputs/
-rw-r--r-- 1 wise wise 0 2009-02-04 19:27 instructions.txt
drwxr-xr-x 2 wise wise 4096 2009-02-04 19:25 outputs/
-rw-r--r-- 1 wise wise 0 2009-02-04 19:26 README
lioff023:/data/lofarschool/data/Exercise_01>
```

Everything in "/data/lofarschool/data" will be write protected. If users want to modify any of the input files or scripts, they can copy them to their working areas.

- Exercise 01A - Station Data
- Exercise 02B - Station Data
- Exercise 03
- Exercise 04
- Exercise 05
- Exercise 06

