



**LOFAR Instrumentation Container
Model: 1700-201**

**Stichting LOFAR
Dwingeloo**



Comtest Engineering bv

Industrieweg 12
2382 NV Zoeterwoude
The Netherlands
Tel: +31.71.5417531
Fax: +31.71.5420375

E-mail: engineering@comtestnl.com

WebSite: www.comtest.eu

Contents

1	INTRODUCTION	4
2	LOFAR INSTRUMENTATION CONTAINER	4
2.1	GENERAL SPECIFICATIONS	5
2.2	RF SPECIFICATIONS.....	6
2.3	LAYOUT OF THE CONTAINER.....	7
2.4	ELECTRICAL LAY-OUT	8
3	DETAILS FOR THE FARADAY CAGE.....	9
3.1	SHIELD CONSTRUCTION	9
3.2	ACCESS DOOR.....	10
3.3	ELECTRIC'S.....	11
3.4	INTERFACE PANELS.....	12
3.5	AIR CONDITIONING SYST EM.....	14
3.6	FINISHING OF SHIELD ROOM.....	15
4.	SERVICE.....	16
4.1	GENERAL	16
4.2	CLEANING OF THE "FINGERSTOCK" MATERIAL.....	16
4.3	CLEANING OF THE DOOR KNIVES.....	17
4.4	REPLACEMENT OF FINGERSTOCK.....	18
5.	SERVICE.....	19

This description is confidential property of COMTEST ENGINEERING BV, Netherlands. It is not to be copied for any purpose without the express written permission of COMTEST.

1 INTRODUCTION

Founded in 1985, Comtest Engineering has provided in-depth EMC test facility planning, engineering and installation services to customers on a world wide basis. Our experience has run the entire spectrum, from design of small shielded rooms through the construction of large Semi Anechoic EMC facilities for testing of satellites and automobiles.

From 1999 Comtest Engineering started with the in-house design and production of shielding. Currently our production facility comprises of an assembly area of 300sqm and production area of 750sqm. Comtest has a flexible and professional organisation and the products are recognised for quality and performance.

Today, Comtest Engineering is well positioned and recognised in the professional shielding field. Comtest offers a single source for planning, design, production and installation of cost effective shielding applications. Based on this experience, Comtest Engineering prepared this solution for the Lofar Instrumentation Container.

2 LOFAR INSTRUMENTATION CONTAINER

For the LOFAR project it was concluded that an air conditioned room is required for the instrumentation. Since the LOFAR stations are often located near very sensitive radio telescope systems, an additional severe requirement is settled for the emission of unwanted signals.

Based on these requirements Comtest selected a 20ft sea container for the primary housing of the instrumentation. Inside the container a high quality shielded enclosure, Faraday Cage, is installed to meet the shielding effectiveness requirements.

To avoid temperature influences on the instrumentation, an isolation barrier is installed between the container walls and the Faraday cage. Additional to this a split type air conditioning system is installed to provide a constant temperature inside the Faraday cage.

The container is equipped with an electrical installation which directly connects to a 3 phase mains power cable. Inside the Faraday cage two separate sections of lights are installed. One with fluorescent lights for service and installation purposes, and a second system which can be used while the system is in operation and no RF disturbance can be tolerated.

2.1 General Specifications

For this application a so-called “High Cube” container is selected.

External cables for antenna’s and mains power are fed into the container through a special entry panel prepared in the floor of the container.

The mounting of the air-conditioning outside unit is done in a special area created on the backside of the container.

General specifications

Outside dimensions:	6058 x 2438 x 2890(h) mm
Colour:	RAL 5011
Total weight:	+/- 3500 kg
Floor entry area:	465 x 685 mm
Electrical connection:	400Vac / 32Amp
Faraday Cage dimensions:	4050 x 2100 x 2535(h) mm
Isolation:	Polyurethane foam around the walls and ceiling of the Faraday Cage. EPS underneath the Faraday Cage.
Air-conditioning system:	Carrier 38GLP split-unit, 7.06kW
Temperature regulation:	20° C +/- 1°
Finishing:	Raised Computer floor



2.2 RF Specifications

The Shielding Effectiveness for the Faraday Cage is measured following the procedure set forward in standard: : EN 50147-1: March 1996.

The results for this container pn: 1700-201 sn 8001 are shown in below table and graph.

The measuring points are located on each side of the container.

Freq.	EN 50147-1	pos 1	pos 2	pos 3	pos 4
10kHz	60	80	95	100	95
100kHz	80	115	115	115	115
1Mhz	100	120	120	120	120
10MHz	100	125	125	125	125
30Mhz	100	105	104	115	110
100MHz	100	102	108	118	110
400MHz	100	120	115	112	118
1000MHz	100	105	104	105	104
10000MHz	75	100	103	104	104

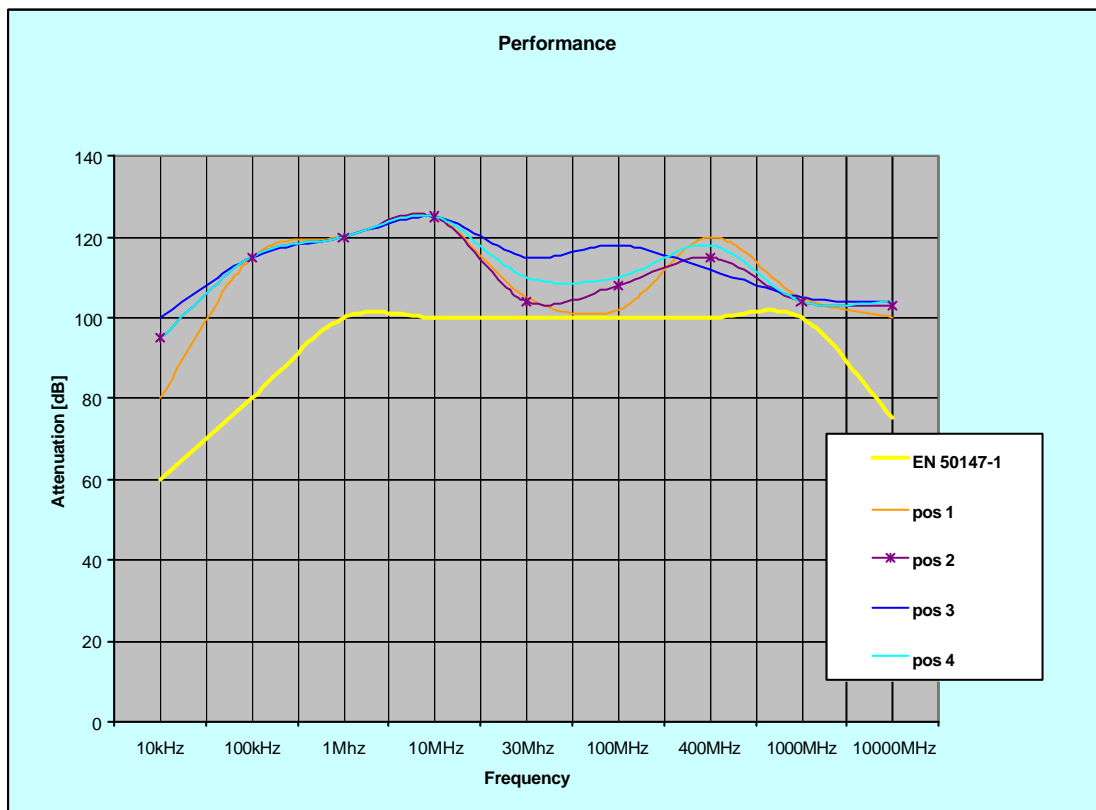

2.3 Layout of the container.

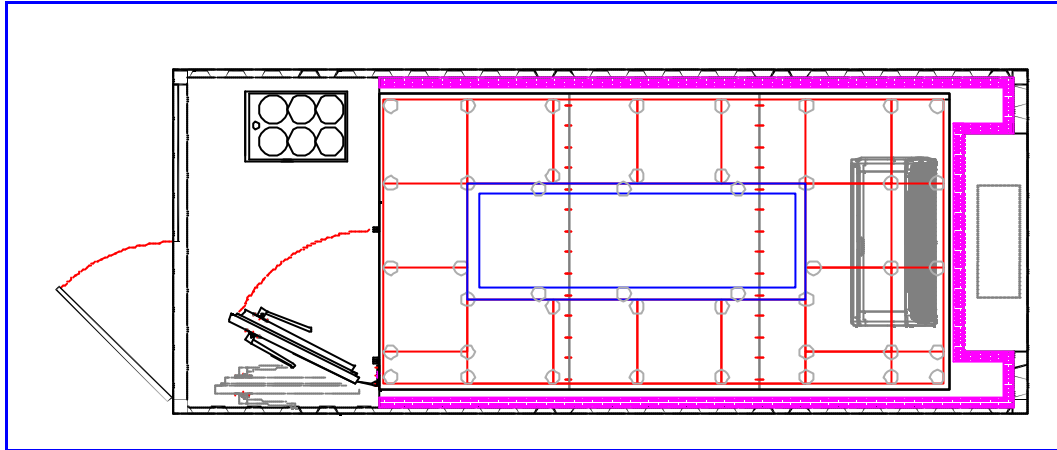

Total overview of the container

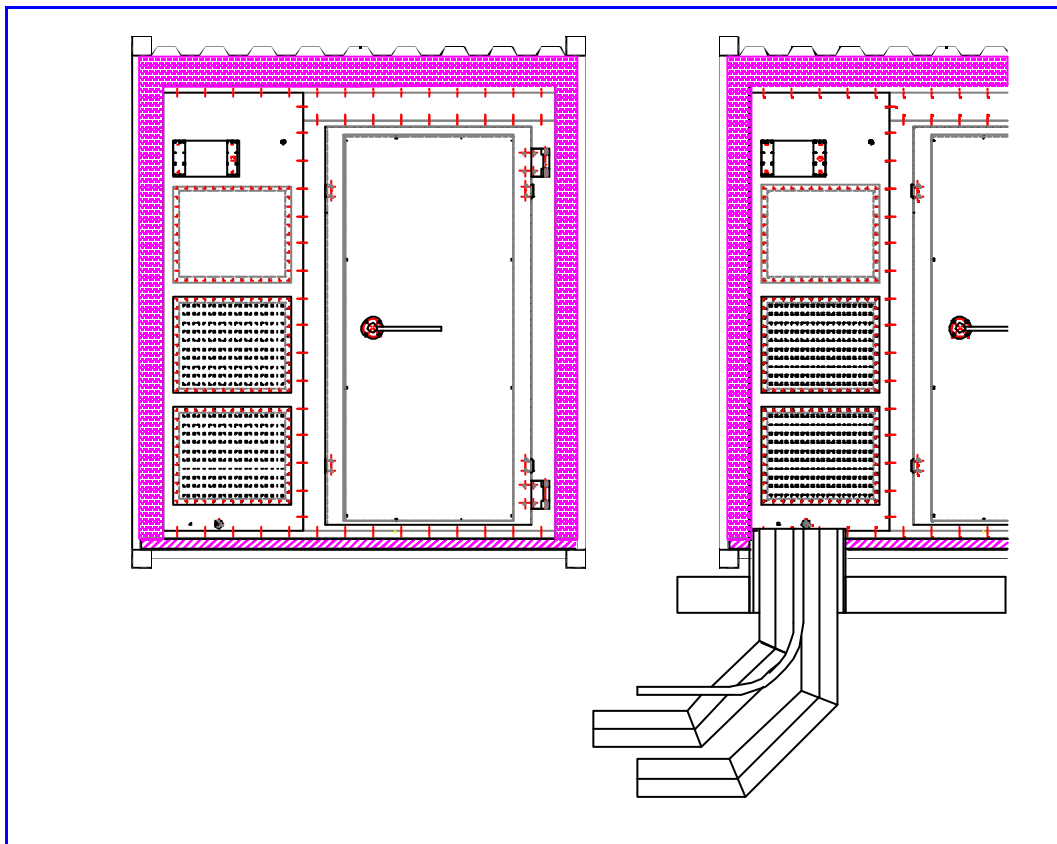

Front of the Faraday Cage

2.4 Electrical lay-out.

The mains power connection is directly routed to the main distribution box installed next the entrance door of the container.

All incoming mains wires are protected against possible surges caused by lightning strokes.

From this distribution box a 3-phase cable is routed to the air conditioning unit. Another cable is connected to the EMC mains powerline filter on the Faraday cage.

Further details can be found on drawing no.: 206141-600

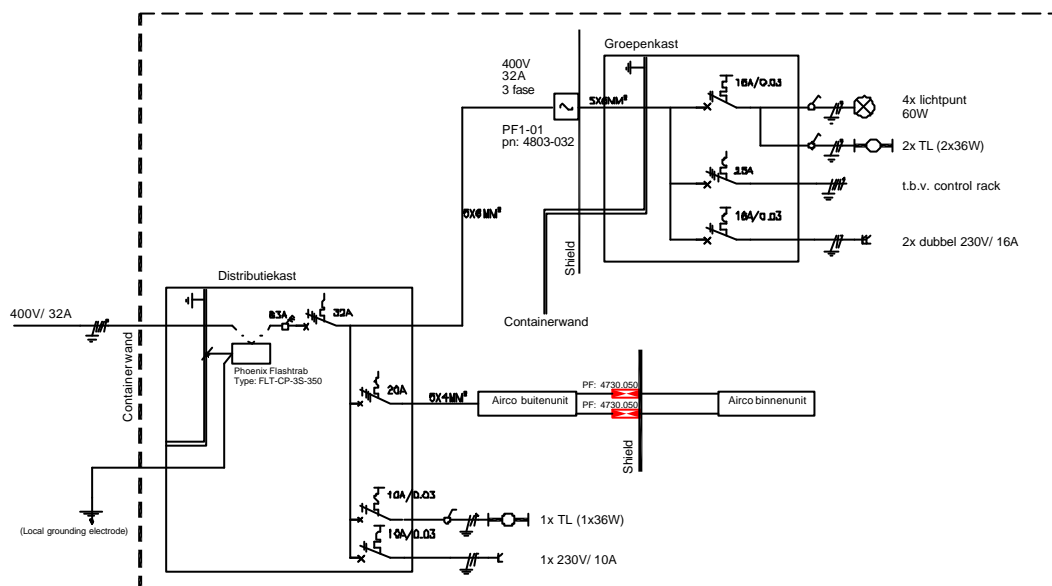

Overview of electrical installation in entrance section

3 Details for the Faraday cage

This section provides further details with reference to the various sections of the Faraday cage.

3.1 Shield construction

The shield of the chamber is constructed using modular Comtest shield panels model 1790-000. These panels are single skin hot galvanised steel panels with 2mm thickness. The panels are bolted together using EMC gasket.

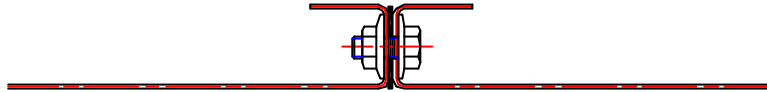

Figure: Pan-Shield type panel construction

3.2 Access door

The swing doors, series 1766-000, are used for personal entrance to shielded rooms. The extended performance doors, series 1766-000 are equipped with a 4-point latching and parallel closing system ensuring longer lifetime of the door components.

The doors can be delivered in manual and semi automatic operation.

In case of mains power breakdown, semi-automatic doors can be operated from the internal rechargeable battery system or using a manual handle which can be installed in the doorknob.

For service purposes the door mechanics can be reached by removing the outside cover of the door. Since this is not an essential part of the shielding it is easy to do all maintenance work without affecting the shielding performance of the Faraday cage.



Example of a 4-points latching door, 1766-series

3.3 Electric's.

In the Faraday cage, a mains distribution box is installed. Several wall outlets are mounted as well as a 3-phase connection for the Lofar Instrumentation racks. Two independent groups of lights are installed. Further details can be found on drawing no.: 206141-600.



Distribution box



Wall outlets

3.4 Interface panels

3.4.1 Coax cable entries

In order to install the coaxial cables three entry panels are located on the front side of the Faraday cage, next to the entrance door. Each panel provides a possibility to connect up to 200 F-type connectors. One panel is currently used as a blank spare panel. See also drawing no.: 206141-500

3.4.2 Air-condition feedtrough's

The connection between the inside and outside units of the air conditioning system is provided using a entry panel. This entry panel is mounted just below the internal air-conditioning unit on the back wall of the Faraday cage.

Details are shown in drawing no.: 206141-505.

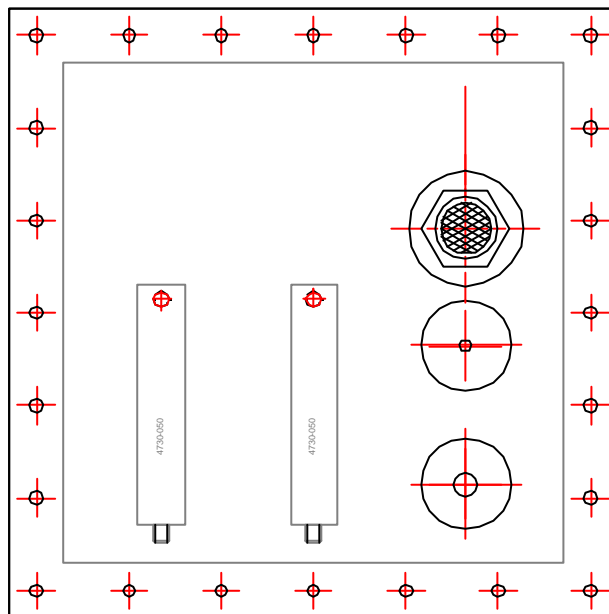

Feedtrough panel for Airco system

3.4.3 Various

Additional provisions are provided on the Faraday cage. A waveguide feedtrough is positioned next to the door in order to easily enter fiber optic cables routed to the Faraday cage. A N-type RF connector is mounted to be used for connection to an GPS antenna for reception of GPS signals inside the Faraday cage.

The Faraday cage is connected to the metal part of the container for safety reasons. In case required additional connections can be made inside the Faraday cage using the earthing point provided.

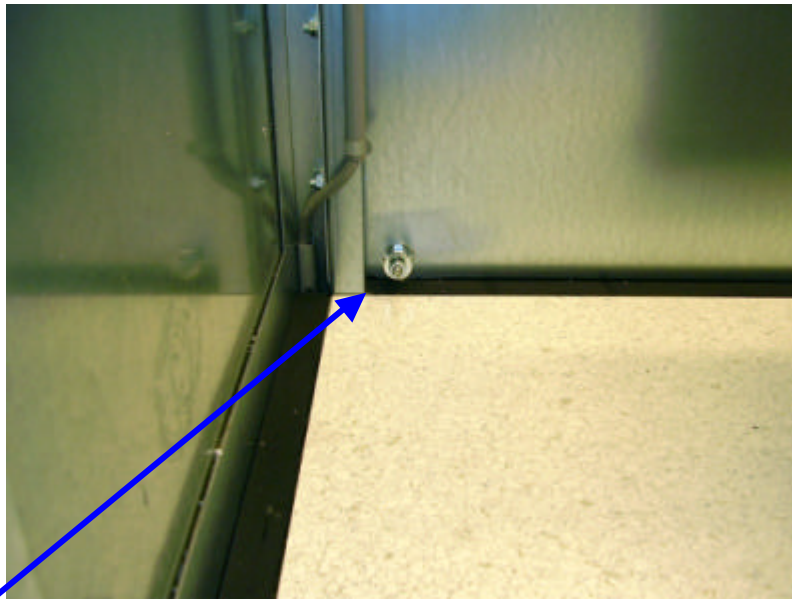

Earthing point

3.5 Air conditioning system

The air conditioning system used is a so called split unit system. The outside section is mounted in a special area to ensure all is within the ISO dimensions of the container. This will reduce the chance of damaging during transport.



The inside unit is mounted on the ceiling of the Faraday cage to provide maximum airflow over the system racks. Using a remote controller, the operator is able to fully adjust the air conditioning system.



3.6 Finishing of shield room

Floor finishing inside the Faraday cage is done by means of a raised computer floor. The free space underneath this floor is 110mm. Coaxial cables from the entry panels can be routed in this area.

In the centre of the room a metal support frame is installed to be used for 19”Inch system rack mounting purposes.

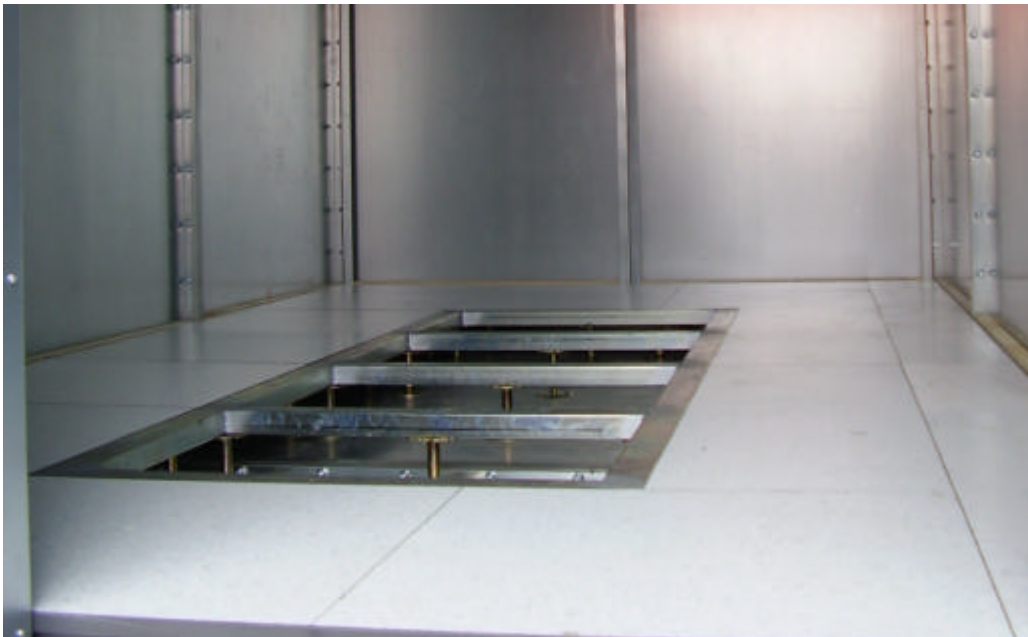

The raised computer floor consist of removable floor tiles, which eases the installation of the coaxial cables.

4. Service

4.1 General.

In this procedure the regular customer maintenance is addressed. By following these instructions shielding deterioration's or malfunction will be prevented. Repair or Maintenance of the moving parts of the locking or opening mechanisms is not recommended to be executed by unauthorized personnel.

Warning

**Do not remove the cover of the door.
Grease may not be used for lubrication of contact surfaces.**

4.2 Cleaning of the “fingerstock” material

Check the fingerstock materials for damaged or de-formed pieces. In case there are broken or de-formed parts, these must be replaced following the instructions in section: 4.4 Fingerstock replacement.

Remove dirt, dust and foreign particles from the door profiles, paying particular attention to the lower U-profile.

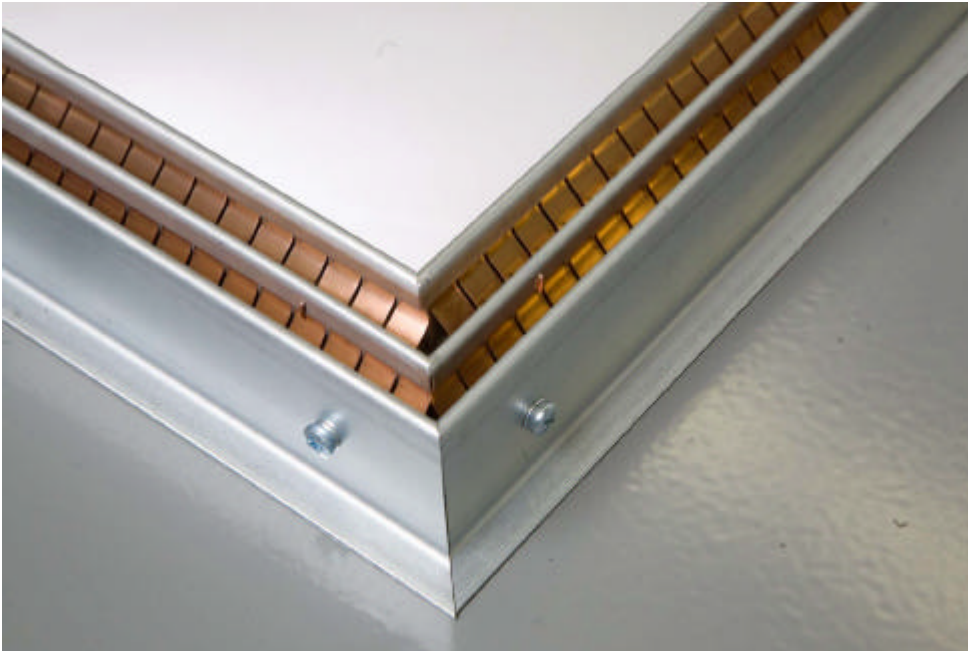

4.3 Cleaning of the door knives.

The contact knife fits in the contact strips when the door is closed. Depending on the type of door, single or double knives exist. Check the contact knives to be straight and parallel with each other. Clean the knives with a soft cloth and little cleaning agent. In case the knives can not be cleaned to be shiny, use "scotch bright" to lightly polish the knives. This completes the maintenance on the door leaf.

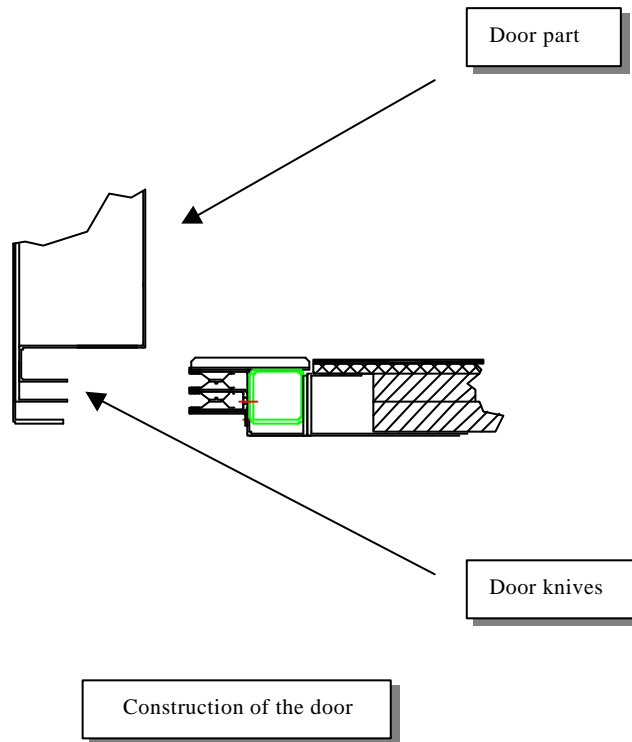

4.4 Replacement of fingerstock.

To replace damaged fingerstock material following tools are required:

Screwdriver
Plastic hammer
Piece of plastic
Fingerstock (pn 1798-xxx)

Following procedure shall be executed:

Remove the safety wires.
Remove the finger strip holder; some force may be needed..
Remove damaged fingerstock piece.
Using a pair of scissors a new piece of fingerstock can be prepared.
Install this new part overlapping the existing section fingerstock (overlapping of approx. 30mm is sufficient)
Mount the fingerstock holder using the plastic tools.
Mount the safety wires

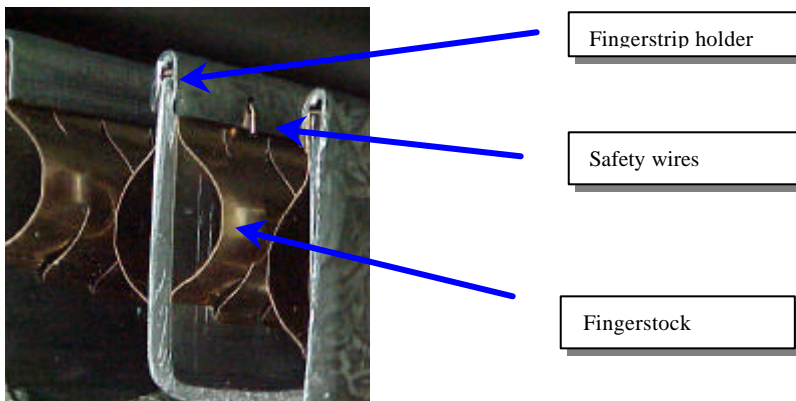

Detail of fingerstock mounting

After installation the service procedure 4.2 & 4.3 shall be executed as described in the previous section of this manual.

5. SERVICE

In order to maintain the shielding effectiveness of the Faraday cage, regular maintenance work shall be carried out at least once a year, or differently depending on the environmental condition. Ordering a preventive service contract will ensure this service is executed by specialists.

A preventive service contract, model: 1580-100 takes care of following issues:

Visual Inspection
Service on the Faraday cage
Shielding Effectiveness measurements

A copy of a preventive service contract can be provided on request.

“ Comtest Onderhoudscontract, model: 1580-100”

In case of problems of emergency repairs please contact :



Industrieweg 12
2382NV Zoeterwoude
Phone: +31 71 5417531
Fax: +31 71 5420375
Email: Engineering@comtestnl.com